

MAGNUM
E N E R G Y

MS-PE Series
Pure Sine Wave
Inverter/Charger



Owner's Manual

MAGNASINETM
MAGNUM

Disclaimer of Liability

The use of this manual and the conditions or methods of installation, operation, use, and maintenance of the MS-PE Series inverter/charger is beyond the control of Magnum Energy, Inc. Therefore, this company assumes no responsibility and expressly disclaims any liability for loss, damage, or expense whether direct, indirect, consequential, or incidental that may arise out of or be in anyway connected with such installation, operation, use, or maintenance.

Due to continuous improvements and product updates, the images shown in this manual may not exactly match the unit purchased.

Restrictions on Use

The MS-PE Series inverter/charger may only be used in life support devices and systems with the express written approval of Magnum Energy. Failure of this inverter can reasonably be expected to cause failure of that life support device or system, or to affect the safety or effectiveness of that device or system. If the MS-PE inverter fails, it is reasonable to assume the health of the user or other persons may be endangered.

Copyright Notice

Copyright © 2013 by Magnum Energy, Inc. All rights reserved. Permission to copy, distribute and/or modify this document is prohibited without express written permission by Magnum Energy, Inc.

Document Information

Description – MS-PE Series Owner’s Manual

Part Number and Revision – 64-0056 Rev A

Date Published – August 2013

This entire manual is available for download—with many of the diagrams available in color—under the Document Library tab at: www.magnumenergy.com.

Contact Information

Magnum Energy, Inc.

2211 West Casino Rd.

Everett, WA 98204

Phone: 011-425-353-8833

Fax: 011-425-353-8390

Web: www.magnumenergy.com

Statement of Appreciation

Thank you from all of us at Magnum Energy for purchasing this MS-PE Series inverter/charger. We understand that you have many purchasing options in the marketplace, and are pleased that you have decided on a Magnum Energy product. This MS-PE Series inverter/charger was proudly assembled and tested in the United States in our Everett, Washington, facility.

At Magnum, we are committed to providing you with quality products and services, and hope that your experience with us is pleasant and professional.

Record the unit’s model and serial number in case you need to provide this information in the future. It is much easier to record this information now, instead of trying to gather it after the unit has been installed.

Model:	Serial Number:
<input type="checkbox"/> MS4124PE	AM
<input type="checkbox"/> MS4348PE	AN

Magnum Energy® is a registered trademark of Magnum Energy, Inc.

IMPORTANT PRODUCT SAFETY INFORMATION

SAVE THESE INSTRUCTIONS

THIS MANUAL CONTAINS IMPORTANT INSTRUCTIONS FOR THE MS-PE SERIES INVERTER/CHARGER THAT SHALL BE FOLLOWED DURING THE INSTALLATION AND OPERATION OF THIS PRODUCT. Before using the MS-PE Series, read all instructions and cautionary markings. Also, be sure to review the individual manuals provided for each component of the system. The installation instructions are for use by qualified personnel only. Do not perform any installation or servicing other than that specified in this owner's manual unless you are qualified to do so. Incorrect installation or servicing may result in a risk of electric shock, fire, or other safety hazard.

Safety Precautions

- This manual contains important safety instructions that must be followed during the installation and operation of this product.
- All electrical work must be performed in accordance with local, state, and federal electrical codes.
- Read all instructions and safety information contained in this manual before installing or using this product.
- This product is designed for indoor/compartment installation. It must not be exposed to rain, snow, moisture, or liquids of any type.
- Use insulated tools to reduce the chance of electrical shock or accidental short circuits.
- Remove all jewelry such as rings, watches, bracelets, etc., when installing or performing maintenance on the inverter.
- Always disconnect the batteries or energy source prior to installing or performing maintenance on the inverter.
- Live power may be present at more than one point since an inverter utilizes both batteries and AC.
- Always verify proper wiring prior to starting the inverter.
- There are no user-serviceable parts contained in this product.
- This unit is provided with integral protection against overloads.
- The input and output AC and DC circuits are isolated from the inverter chassis. The inverter system grounding is the responsibility of the installer in accordance with industry standards and local codes.
- Both AC and DC overcurrent protection **must** be provided as part of the installation.
- Use Class 1 wiring methods for field-wiring connections to terminals of a Class 2 circuit.
- Use only copper wires with a minimum temperature rating of 90°C.
- Listed or labeled equipment shall be installed and used in accordance with any instructions included in the listing or labeling.

Product Safety Information

Battery Safety

- Be very careful when working around batteries, they can produce extremely high currents if short-circuited. Read the battery supplier's precautions before installing the inverter and batteries.
- Wear eye protection such as safety glasses when working with batteries.
- Remove all jewelry such as rings, watches, bracelets, etc., when installing or performing maintenance on the battery.
- Never work alone. Always have someone near you when working around batteries.
- Use proper lifting techniques when working with batteries.
- Never use old or untested batteries. Check each battery's label for age, type, and date code to ensure all batteries are identical.
- Batteries are sensitive to changes in temperature. Always install batteries in a stable environment.
- Install batteries in a well-ventilated area. Batteries can produce explosive gases. For compartment or enclosure installations, always vent batteries to the outside.
- Provide at least 2.5 cm (1") of air space between batteries to provide optimum cooling.
- Never smoke in the vicinity of batteries.
- To prevent a spark at the battery and reduce the chance of explosion, always connect the cables to the batteries first. Then connect the cables to the inverter.
- Use insulated tools at all times.
- Always verify proper polarity and voltage before connecting the batteries to the inverter.
- To reduce the chance of fire or explosion, do not short-circuit the batteries.
- In the event of accidental exposure to battery acid, wash thoroughly with soap and water. In the event of exposure to the eyes, flood them for at least 15 minutes with running water and seek immediate medical attention.
- Recycle old batteries.

Safety Symbols

The following safety symbols have been placed throughout this manual to indicate dangerous and important safety instructions.



WARNING: This symbol indicates that failure to take a specified action could result in physical harm to the user.



CAUTION: This symbol indicates that failure to take a specified action could result in damage to the equipment.



Info: This symbol indicates information that emphasizes or supplements important points of the main text.

Table of Contents

1.0	Introduction	1
1.1	Regulatory Compliance	1
1.2	How an Inverter/Charger Works	2
1.2.1	Inverter Applications for Permanent Installations	2
1.2.2	Inverter Applications for Mobile Installations	2
1.3	Advantages of using a Pure Sine Wave Inverter	2
1.4	Features and Benefits	3
2.0	Installation	6
2.1	Pre-Installation	6
2.1.1	Unpacking and Inspection	6
2.1.2	Required Tools and Materials	6
2.1.3	Locating the Inverter	8
2.2	Mounting the Inverter	9
2.3	Wiring the Inverter – General Requirements	11
2.3.1	Protecting Wire – Conduit Box or Inverter Enclosure	11
2.3.2	Wiring Requirements	11
2.3.3	Wire Routing	11
2.3.4	Torque Requirements	11
2.4	DC Wiring	12
2.4.1	DC Wire Sizing	14
2.4.2	DC Overcurrent Protection	14
2.4.3	DC Cable Connections	15
2.4.4	Wiring the Battery Bank	16
2.4.5	Battery Temperature Sensor Installation and Wiring	16
2.4.6	Wiring the Inverter to the Battery Bank	17
2.5	AC Wiring	18
2.5.1	Pre-AC Wiring Requirements	18
2.5.2	AC Wire Size and Overcurrent Protection	18
2.5.3	AC Terminal Block Connections	19
2.5.4	AC Conductor Wiring	20
2.5.5	AC Wiring Configuration	20
2.6	Grounding Inverters	22
2.6.1	Sizing the Grounding Electrode Conductors	23
2.6.2	System Bonding Jumper	25
2.6.3	Equipment Grounding Conductor	25
2.6.4	Grounding on Boats	26
2.6.5	Neutral to Safety Ground Bonding	27
2.6.6	Disabling the Neutral-to-Ground Connection	28
2.6.7	Connecting a Large Ground Wire	28
2.7	Inverter Notification Requirements	29
2.7.1	Inverter Warning Label	29
2.8	Final Inspection	29
2.9	Functional Test	30

Table of Contents (cont.)

3.0 Operation	31
3.1 Inverter Mode	31
3.2 Standby Mode	32
3.3 Battery Charging	32
3.4 Transfer Time	34
3.5 Battery Temperature Sensor Operation	34
3.6 Protection Circuitry Operation	35
3.7 Inverter Startup	36
3.8 Factory Default Values	37
3.9 Inverter Fan Operation	38
3.10 Using a Remote with the MS-PE Series Inverter	38
3.10.1 Remote Compatibility	38
3.11 Parallel Operation	39
3.11.1 Overview	39
3.11.2 Parallel System Connections and Components	41
4.0 Maintenance and Troubleshooting	42
4.1 Recommended Inverter and Battery Care	42
4.2 Storage for Mobile Installations	42
4.3 Troubleshooting	43
4.4 Resetting the Inverter	44
4.4.1 Performing an Inverter Reset	44
4.4.2 Performing a Power Reset	44
Appendix A – Specifications and Optional Equipment	45
A-1 Inverter/Charger Specifications	45
A-2 Optional Equipment and Accessories	46
A-3 Wiring Color Codes for Europe and the U.S./Canada	47
Appendix B - Battery Information	48
B-1 Battery Location	48
B-2 Battery Types	48
B-3 Battery Temperature	48
B-4 Battery Bank Sizing	48
B-5 Battery Bank Sizing Worksheet	49
B-6 Battery Wiring Configurations	50
B-6.1 Series Wiring	50
B-6.2 Parallel Wiring	50
B-6.3 Series-Parallel Wiring	50
Appendix C – Power Consumption and Output Waveforms	53
C-1 Appliance Power Consumption	53
C-2 Inverter Output Waveforms	53
Appendix D – Inverter/Charger Terminology	54
Appendix E – Warranty and Service Information	56
E-1 Limited Warranty	56
E-2 How to Receive Repair Service	56

List of Figures

Figure 1-1, Power Switch, Status LED, and Accessory Connection Ports.....	3
Figure 1-2, Electrical Connection Points	4
Figure 1-3, Left Side Features	5
Figure 2-1, Simplified Installation Diagram – Single Inverter	7
Figure 2-2, Approved Mounting Positions	9
Figure 2-3, MS-PE Series Dimensions and Side Reference	10
Figure 2-4, DC and Battery Temperature Sensor Wiring	13
Figure 2-5, Battery Hardware Installation	15
Figure 2-6, Inverter DC Hardware Installation	15
Figure 2-7, Battery Temperature Sensor	16
Figure 2-8, AC Terminal Block	19
Figure 2-9, AC Wiring Input/Output	21
Figure 2-10, Grounding System for MS-PE Series.....	22
Figure 2-11, Multiple Connections to DC Ground Rod (Method 1).....	23
Figure 2-12, Multiple Connections to DC Ground Rod (Method 2).....	24
Figure 2-13, Single Connection to DC Ground Rod (Method 3)	24
Figure 2-14, Neutral-to-Ground Connection (Inverter Mode).....	27
Figure 2-15, Neutral-to-Ground Connection (Standby Mode).....	27
Figure 2-16, Disconnecting the Neutral-to-Ground Connection	28
Figure 2-17, Large Ground Wire Connected to MS-PE Series.....	28
Figure 2-18, Warning Label.....	29
Figure 2-19, AC Voltage Checks.....	30
Figure 3-1, Power Flow - Inverter Mode	31
Figure 3-2, Power Flow - Standby Mode.....	32
Figure 3-3, Automatic 4-Stage Charging Graph.....	33
Figure 3-4, BTS Temperature to Charge Voltage Change	34
Figure 3-5, Power Switch and Status Indicator.....	36
Figure 3-6, Simplified Installation Diagram – Multiple Inverters (in parallel).....	40
Figure 3-7, Simplified Magnum Panel (AC Panel)	41
Figure 3-8, Simplified Magnum Panel (DC Panel).....	41
Figure 4-1, Performing an Inverter Reset	44
Figure B-1, Series Battery Wiring.....	50
Figure B-2, Parallel Battery Wiring	50
Figure B-3, Series-Parallel Battery Wiring	50
Figure B-4, Battery Bank Wiring Examples (24-volt).....	51
Figure B-5, Battery Bank Wiring Examples (48-volt).....	52
Figure C-1, AC Waveforms	53

List of Tables

Table 2-1, Recommended DC Wire/Overcurrent Device for Rated Use	14
Table 2-2, DC Wire Size For Increased Distance	15
Table 2-3, AC Grounding Electrode Conductor Sizing	23
Table 2-4, Equipment Grounding Conductor Sizing	25
Table 3-1, Inverter Battery Turn On/Off Levels.....	35
Table 3-2, Inverter/Charger Default Values	37
Table 3-3, Inverter Compatibility Level	38
Table 3-4, Remote Compatibility Level	38
Table 4-1, Basic Troubleshooting (remote not available).....	43
Table A-1, AC Wiring Color Codes.....	47
Table A-2, DC Wiring Color Codes	47
Table C-1, Typical Appliance Power Consumption.....	53

Introduction

1.0 Introduction

Congratulations on your purchase of a MS-PE Series inverter/charger from Magnum Energy. The MS-PE Series is a “pure” sine wave inverter designed especially for rugged mobile applications, home backup power, and standalone applications that require 230 VAC/50 Hz power. Powerful, yet simple to use, this inverter/charger will provide you with years of trouble-free performance you have come to expect from Magnum Energy.

When the power requirements of the system are beyond the capacity of a single MS-PE Series inverter or the system is expanded as more loads are added, up to four MS-PE Series inverters can be connected together in a parallel configuration. Connecting inverters in parallel increases the overall inverter power and surge capacity to power a large single load or several smaller loads.



Info: This is a sizeable manual and much of it is fairly technical. Terms may be used throughout the manual that are unfamiliar to you. Refer to the Inverter/Charger Terminology glossary in Appendix D for clarification.

The MS-PE Series inverter/charger includes the following:

- 4100 or 4300-watt models in a small footprint installation
- Ability to parallel up to four identical MS-PE inverters to increase output power capability
- Automatic Power Factor Corrected (PFC) multi-stage battery charging
- RS485 standard communication protocol
- Remote and Network ports (easy connection for optional accessories)
- Inverter-mounted ON/OFF switch with LED indicator
- 30-amp AC pass-thru capability
- DC terminal covers with 360 degree connection
- Field-serviceable for qualified personnel—tested repair kits available
- Automatic battery temperature compensation (using a battery temperature sensor)—for optimum charging even during extreme temperature changes
- Overcurrent, over-temperature, and high/low battery voltage protection



Info: Refer to the Optional Equipment and Accessories section in Appendix A-2 for a list of accessories available for use with your MS-PE Series inverter/charger.

1.1 Regulatory Compliance

MS-PE Series inverter/chargers—when connected to a MS-CEFB (CE Filter Box)—meets the CE Mark requirements as attested by conformity to the following EU directives and standards:

EMC Directive 1999/5/EEC, per:

- *EN 55014-1 (2006) +A1, +A2 (>1000W)*: Electromagnetic compatibility – Requirements for household appliances, electric tools, and similar apparatus – Part 1: Emission
- *EN 55014-2 (1997) +A1, +A2*: Electromagnetic compatibility – Requirements for household appliances, electric tools and similar apparatus – Part 2: Immunity – Product family standard
- *EN 61000-3-2 (2006) +A1, +A2*: Electromagnetic compatibility (EMC) – Part 3-2: Limits – Limits for harmonic current emissions (equipment input current ≤ 16 A per phase)
- *EN 61000-3-3 (2008)*: Electromagnetic compatibility (EMC) – Part 3-3: Limits – Limitation of voltage changes, voltage fluctuations and flicker in public low-voltage supply systems, for equipment with rated current ≤ 16 amps per phase and not subject to conditional connection

Also meets the C-Tick Mark requirement as attested by conformity with the standards for:

- *AS/NZS CISPR 14-1:2005*

1.2 How an Inverter/Charger Works

There are two main modes of operation associated with the MS-PE inverter/charger:

- **Inverter Mode:**
When the inverter is properly connected to batteries and turned on, the direct current (DC) from the batteries is transformed into a pure sine wave alternating current (AC). This AC is similar to the voltage provided by your utility, and is used to power the electrical appliances (i.e., AC loads) connected to the inverter's output.
- **Standby Mode:**
When an external source of AC power (e.g., utility power or generator) is connected and qualified on the inverter's AC input, it operates in Standby mode. In Standby mode, the unit operates as a battery charger to convert the incoming AC power into DC power to recharge the batteries; while at the same time, automatically closing an internal AC transfer relay to pass the incoming AC power directly to the inverter's output to continue powering the connected electrical appliances.

1.2.1 Inverter Applications for Permanent Installations

An inverter can be used for backup power in a permanent location that normally uses utility power, such as a home or office. When utility power is available, the inverter keeps the batteries charged. When the utility power fails, the inverter comes on automatically to supply AC power to your home or office during the power failure. For a home or business, reliable backup power is needed to prevent lost computer data, or to maintain lights and keep food fresh in the refrigerator/freezer. In some areas, where utility power is not available, the inverter can be used in a standalone renewable power system. The inverter enables AC electrical appliances to be run from the storage battery bank. When the battery bank becomes discharged, either renewable DC sources (solar, wind, or hydropower) can be used to recharge the batteries, or a generator can be connected to the inverter to power the system while the batteries recharge.

1.2.2 Inverter Applications for Mobile Installations

Inverters can also be used to provide power in mobile applications (e.g., caravans or boats). In these applications, the inverter provides power to the AC loads using the energy stored in the batteries and recharges the batteries when shorepower or an onboard generator is available.

1.3 Advantages of using a Pure Sine Wave Inverter

Today's inverters come in three basic output waveforms: square wave, modified sine wave (which is actually a modified square wave), and pure sine wave (see Figure C-1 in Appendix C). Modified sine wave inverters approximate a pure sine wave form and will run most appliances (see also Section C-1 "Appliance Power Consumption" in Appendix C) and electronics without any problems. These inverters are less expensive, and therefore, offer a viable alternative to more expensive pure sine inverters.

The output of the MS-PE Series, which is a pure sine wave inverter, is equal to or in many cases, better than the utility power used in your home. Virtually any electronic device will operate from a pure sine wave inverter. Motors run cooler, microwaves usually cook faster, and clocks keep better time just to name a few examples. Without compromising quality or performance, the MS-PE Series provides you with all the advantages of a pure sine wave inverter at a much lower cost than many on the market.



The MS-PE Series is built on the same platform as our popular MS Series which helps reduce cost by using standard parts/accessories across many models. Magnum accessories such as the Advanced Remote Control (ME-ARC50), Standard Remote Control (ME-RC50), Automatic Generator Start-Networked (ME-AGS-N), and Battery Monitor Kit (ME-BMK) can be used. See Section A-3 "Optional Equipment and Accessories" for more information on these products.

Introduction

1.4 Features and Benefits

The MS-PE Series inverter/charger is designed to allow easy access to wiring, circuit breakers, and controls. Its die cast baseplate with one-piece aluminum cover ensures maximum durability with minimum weight, as well as cooler, more efficient operation.

The front of the MS-PE Series is equipped with the following features (see Figures 1-1 and 1-2):

- 1 **Power ON/OFF Switch** – a momentary pushbutton switch that alternately turns the inverter on or off.
 - 2 **Status LED Indicator** – this green LED illuminates to provide information on inverter or charger operation.
 - 3 **Stack/Accessories Port (red label)** – a RJ45 port that connects to the ME-RTR router, which is used to configure and synchronize multiple MS-PE units to operate in parallel for increased power capacity.
-  **CAUTION:** Only connect this parallel stack port to the ME-RTR router. Although the cabling and connectors used in this network system are the same as ethernet connectors, this network is not an Ethernet system. Attempting to connect these two different systems may cause damage and is not covered under warranty.
-  **Info:** To connect MS-PE Series inverters in parallel, the optional ME-RTR router must be installed.
- 4 **Network Port (green label)** – a RJ11 port for connecting optional network capable accessories (e.g., Auto Gen Start module or Battery Monitor).
 - 5 **Remote Port (blue label)** – a RJ11 port for connecting the optional remote controls (ME-RC, ME-ARC, or ME-RTR).
 - 6 **Battery Temp Sensor Port (yellow label)** – a RJ11 port for connecting the remote Battery Temperature Sensor (BTS) accessory.

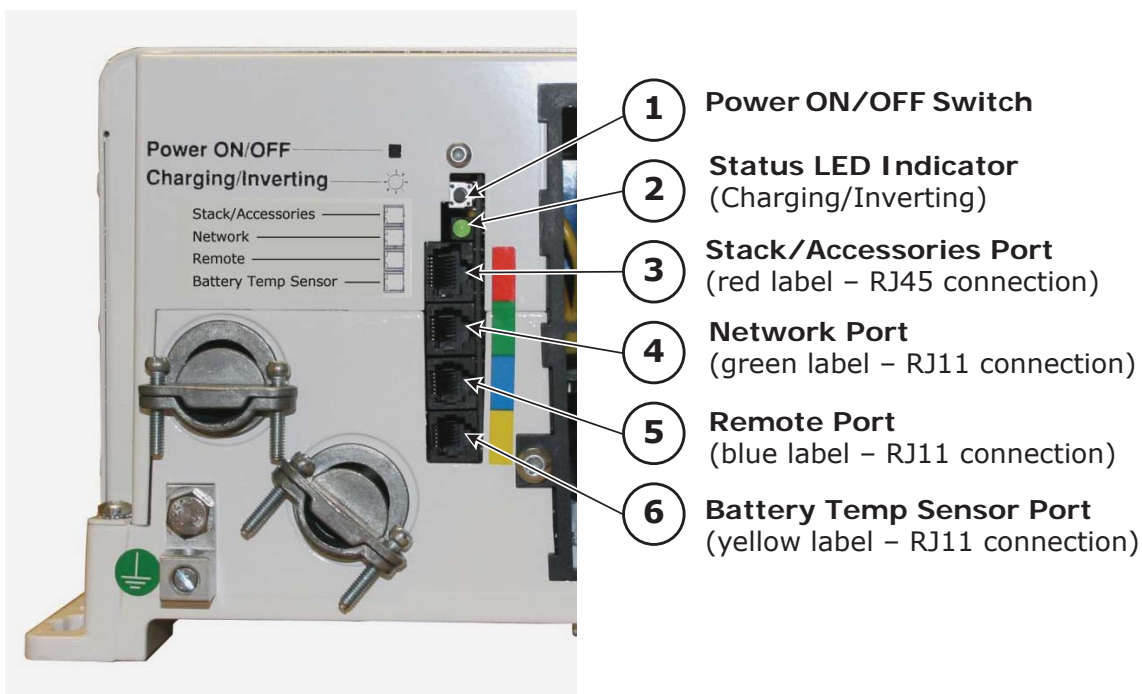

Figure 1-1, Power Switch, Status LED, and Accessory Connection Ports

- 7 **DC Equipment Ground Terminal** – this connection is used to tie the exposed chassis of the inverter to the DC grounding system. This terminal accepts CU/AL conductors from 2.1 to 33.6 mm² (#14 to #2 AWG).
- 8 **AC Entry/Exit Connections** – two 3/4" knockouts provided with cable-clamp strain reliefs to accommodate and secure the AC input and output field wiring.
- 9 **Intake Air Vents** – ventilation openings to pull in air to help keep the inverter cool for peak performance. The intake air vents are located on the front side and at the front on the right side; see Figure 2-3 for the locations of the air vents.
- 10 **Positive DC Terminal (red)** – provides a 360 degree connection point for the positive (+) cable from the battery bank; consists of a 5/16-18 x 5/8" bolt with a Kep or Flange nut that holds the battery cable to the DC terminal.
- 11 **Negative DC Terminal (black)** – provides a 360 degree connection point for the negative (-) cable from the battery bank; consists of a 5/16-18 x 5/8" bolt with a Kep or Flange nut that holds the battery cable to the DC terminal.
- 12 **Mounting Flange** – used to secure the inverter to a shelf or to a wall.

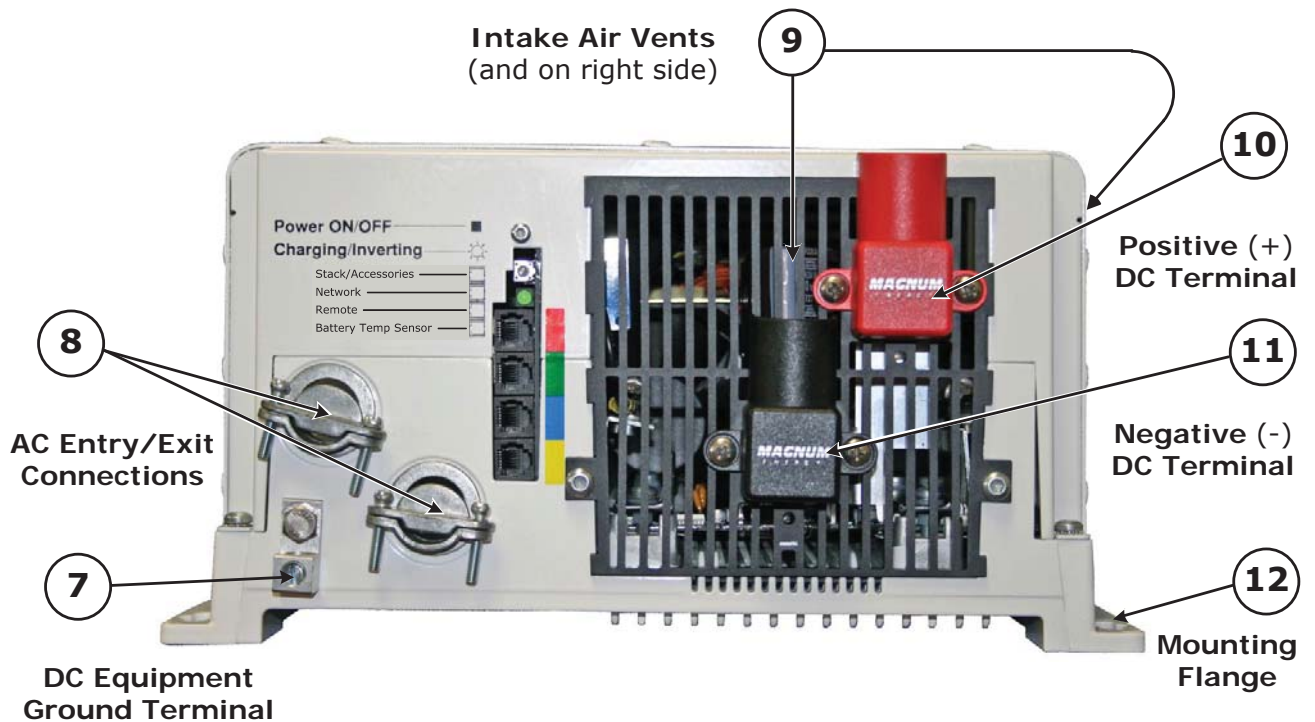

Figure 1-2, Electrical Connection Points

Introduction

The left side of the MS-PE Series inverter is equipped with the following features (see Figure 1-3):

- 13 Exhaust Air Vents** – ventilation openings that allow heated air to be removed by the internal cooling fan. The exhaust air vents are located on the back side and at the rear on the right side; see Figure 2-3 for the location of the air vents.
- 14 Model/Serial Number Label** – includes model/serial number information, date of manufacture, and inverter and charger specifications. See the MS-PE Specifications section in Appendix A for more information and a list of available models.
- 15 AC Access Cover** – provides access to the internal AC wiring terminal block. This terminal block is used to hardwire all inverter AC input and output wiring connections. Remove the two screws to access the AC wiring terminal block.
- 16 AC Input Circuit Breaker (CB1)** – this circuit breaker protects the unit's internal charger wiring and pass-thru relay while in Standby mode. The circuit breaker pops out when it opens—press in to reset. The input circuit breaker is not branch-rated, therefore branch-rated circuit breakers must be installed in the inverter's input and output wiring.



CAUTION: The inverter's internal AC transfer relay is rated for 30 amps. The pass-thru current must be no greater than 30 amps, or damage to the relays may occur.

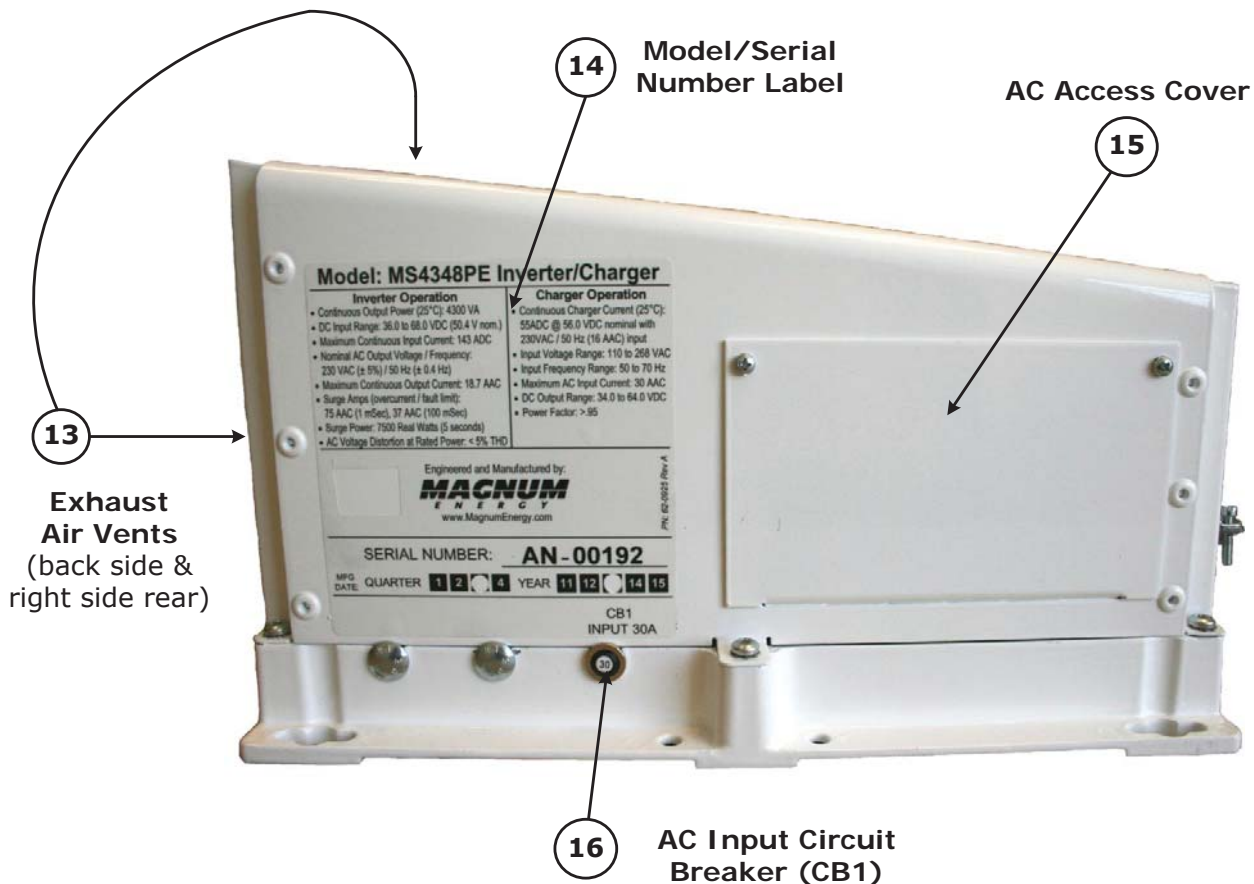

Figure 1-3, Left Side Features

2.0 Installation



WARNING: Installations should be performed by qualified personnel, such as a licensed or certified electrician. It is the installer's responsibility to determine which safety codes apply and to ensure that all applicable installation requirements are followed. Applicable installation codes vary depending on the specific location and application of the installation.



CAUTION: Review the "Important Product Safety Information" on pages ii-iii before any installation.



CAUTION: The inverter is heavy. Use proper lifting techniques during installation to prevent personal injury.

The simplified system diagram shown in Figure 2-1 should be reviewed to assist you in planning and designing your installation. This drawing is not intended to override or restrict any national or local electrical codes. This drawing should not be the determining factor as to whether the installation is compliant, that is the responsibility of the electrician and the on-site inspector.

2.1 Pre-Installation

Before proceeding, read the entire Installation section to determine how best to install your MS-PE inverter/charger. The more thorough you plan in the beginning, the better your inverter needs will be met.

2.1.1 Unpacking and Inspection

Carefully remove the MS-PE Series inverter/charger from its shipping container and inspect all contents. Verify the following items are included:

- The MS-PE inverter/charger
- Red and black DC terminal covers with Phillips screws
- AC access cover with two Phillips screws
- Two 5/16" Kep or Flange nuts (installed on the DC terminals)
- Battery Temperature Sensor
- Warning label
- MS-PE Series Owner's Manual

If items appear to be missing or damaged, contact your authorized Magnum Energy dealer or Magnum Energy. If at all possible, keep your shipping box to help protect your inverter from damage if it ever needs to be returned for service. Save your proof-of-purchase as a record of your ownership; it will also be needed if the unit should require in-warranty service.

Record the unit's model and serial number in the front of this manual in case you need to provide this information in the future. It is much easier to record this information now, instead of trying to gather it after the unit has been installed.

2.1.2 Required Tools and Materials

Hardware/Materials

- Conduit, strain-reliefs, and appropriate fittings
- Electrical tape
- 1/4" mounting bolts and lock washers
- Wire ties

Tools

- Miscellaneous screwdrivers
- Drill and drill bits
- Level
- Pliers
- Pencil or marker
- 13 mm (1/2") wrench
- Wire strippers
- Multimeter

Installation

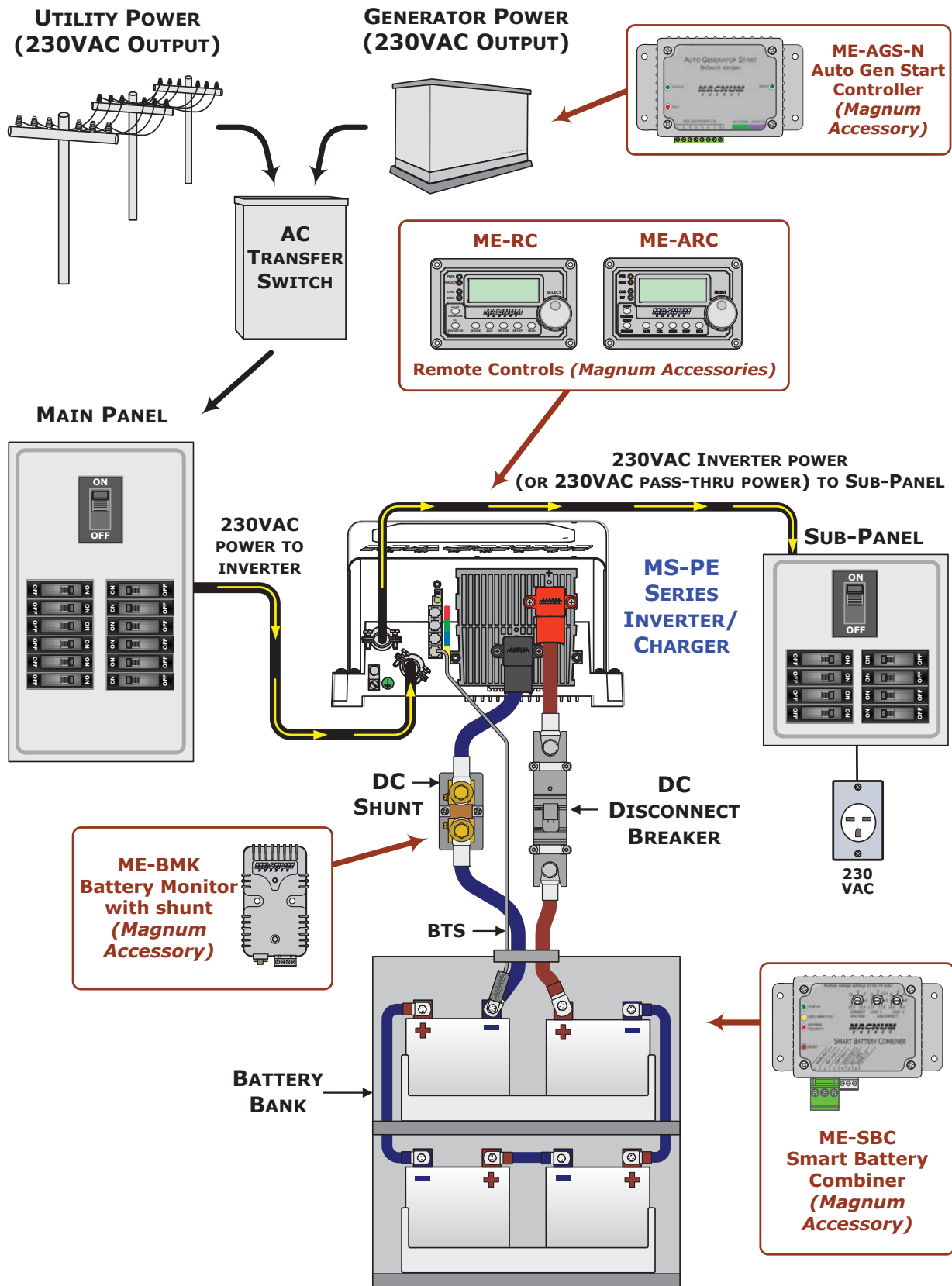

Figure 2-1, Simplified Installation Diagram – Single Inverter

2.1.3 Locating the Inverter

Only install the inverter in a location that meets the following requirements:

Clean and Dry – The inverter should not be installed in an area that allows dust, fumes, insects, or rodents to enter or block the inverter's ventilation openings. This area also must be free from any risk of condensation, water, or any other liquid that can enter or fall on the inverter. The inverter uses stainless steel fasteners, plated copper busbars, a power-coated aluminum base, and the internal circuit boards are conformal coated—to help fight the harmful effects of corrosive environments. However, the inverter's life is uncertain if used in the above types of environments, and inverter failure due to any of the above conditions is not covered under warranty.



Info: If the inverter is installed in an area where moisture may occur, we recommend putting silicone dielectric grease compound into the electrical ports (see Figure 1-1, Items 3-6). Before installing the cables, or if leaving any ports open, squirt a liberal amount into each port. Silicone dielectric compound makes an effective moisture and corrosive barrier to help protect and prevent corrosion to the RJ11 connections.

Cool – The inverter should be protected from direct sun exposure or equipment that produces extreme heat. The ambient temperature around the inverter must not exceed 25°C (77°F) to meet power specifications.

Ventilation – In order for the inverter to provide full output power and to avoid over-temperature fault conditions, do not cover or block the inverter's ventilation openings or install this inverter in an area with limited airflow. The inverter uses two fans to provide forced air cooling, these fans pull in air through the intake vents (see Figure 1-2, Item 9) and blow out air through the exhaust vents (see Figure 1-3, Item 13). Allow at the minimum an airspace clearance of 15.2 cm (6") at the intake and exhaust vents, and 7.6 cm (3") everywhere else to provide adequate ventilation.

If installed in an enclosure, a fresh air intake opening must be provided directly to the inverter's front side (intake vents) and an exhaust opening for the inverter's back side (exhaust vents). This allows cool air from the outside to flow into the inverter, and heated air to exit the inverter and the enclosure. When mounted in an enclosed compartment, airflow must be ≥ 100 cfm in order to maintain no more than a 20°C (68°F) rise in compartment temperature.



CAUTION: Do not mount this inverter in a zero clearance compartment, nor cover or obstruct the ventilation openings—overheating may result.

Safe – Keep any flammable/combustible material (e.g., paper, cloth, plastic, etc.,) that may be ignited by heat, sparks, or flames at a minimum distance of 61 cm (2 ft) away from the inverter.

Close to the battery bank – The inverter should be located as close to the batteries as possible. Long DC wires tend to lose efficiency and reduce the overall performance of an inverter. However, the unit should NOT be installed in the same compartment as the batteries or mounted where it will be exposed to gases produced by the batteries. These gases are corrosive and will damage the inverter; also, if these gases are not ventilated and allowed to collect, they could ignite and cause an explosion.

Accessible – Do not block access to the inverter's remote control and accessory ports, as well as the inverter's controls and status indicator. Allow enough room to access the AC and DC wiring terminals and connections, as they will need to be checked and tightened periodically. See Figure 2-3 for the MS-PE Series' inverter/charger dimensions.

Away from sensitive electronic equipment – High-powered inverters can generate levels of RFI (Radio Frequency Interference). Locate any electronic equipment susceptible to radio frequency and electromagnetic interference as far away from the inverter as possible.

Installation

2.2 Mounting the Inverter

The inverter base can reach a temperature up to 90°C (194°F) and should be mounted on a non-combustible surface*. This surface and the mounting hardware must also be capable of supporting at least twice the weight of the inverter. To meet regulatory requirements, the MS-PE Series must be mounted in one of the following positions (as shown in Figure 2-2):

- above or under a horizontal surface (shelf or table),
- on a vertical surface (wall) with the DC terminals to the right,
- on a vertical surface (wall) with the DC terminals toward the bottom, the MP-HOOD (inverter hood) installed on the top, and one of the following installed on the bottom: ME-CB or MPX-CB (conduit boxes), MS-CEFB (CE filter box), MMP-E Series (single inverter enclosure), or MP-E Series (multiple inverter enclosure).



Info: The ME-CB, MPX-CB, MS-CEFB, MMP-E and MP-E enclosures all prevent material from falling out the bottom in the event of an internal fire. The MP-HOOD inverter hood prevents items from falling inside, causing damage to the inverter.



Info: Magnum provides a backplate for mounting the inverter. These backplates also provide the ability to mount either the MMP-E Series enclosure (PN: BP-MMP) or the MP-E Series enclosure (PN: BP-S single plate, or BP-D dual plate).

After determining the mounting position, refer to the physical dimensions as shown in Figure 2-3, or use the base of the inverter as a template to mark your mounting screw locations. After marking the mounting screw locations, mount the unit with appropriate mounting hardware.

* *Non-combustible surface – A surface made of material that will not ignite, burn, support combustion, or release flammable vapors when subjected to fire or heat as per the ASTM E136 standard. For the most part, these are materials that are largely comprised of inorganic materials such as stone, steel, iron, brick, tile concrete, slate, and glass. Avoid common building materials such as gypsum board, painted surfaces, wall coverings, and any type of wood.*

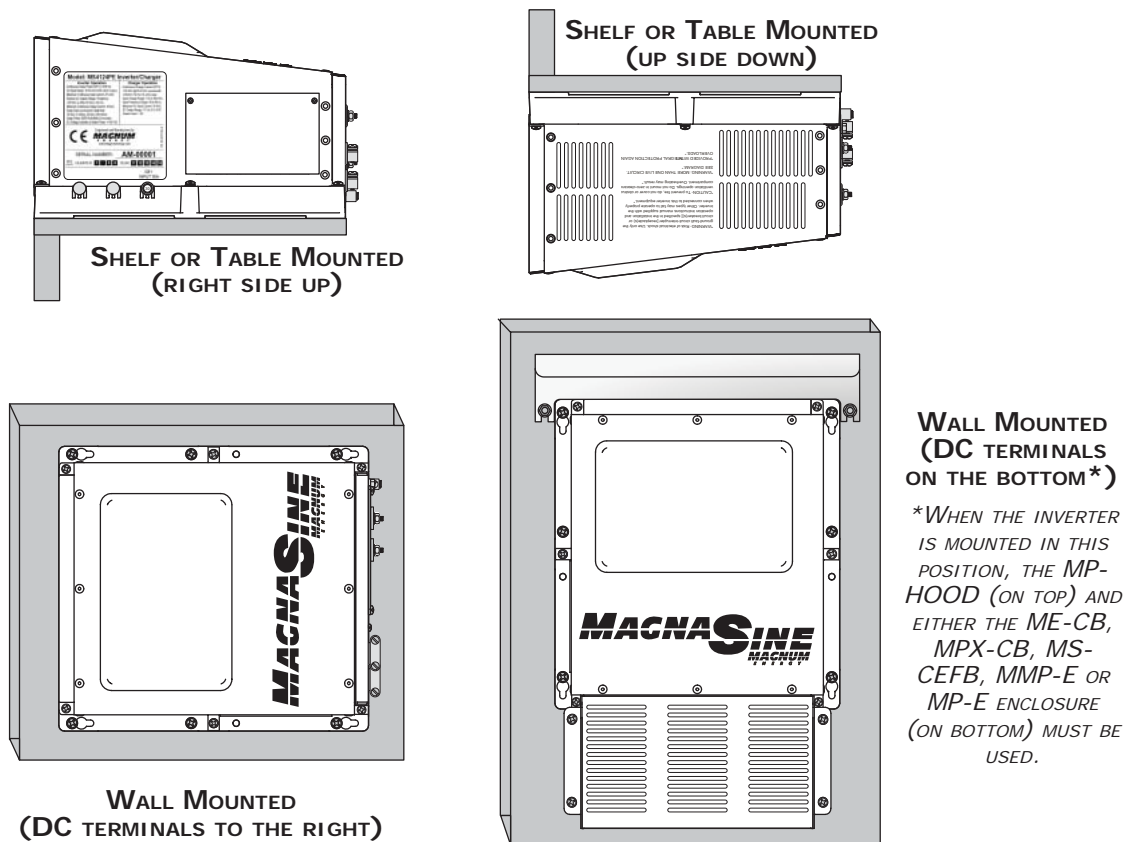

Figure 2-2, Approved Mounting Positions

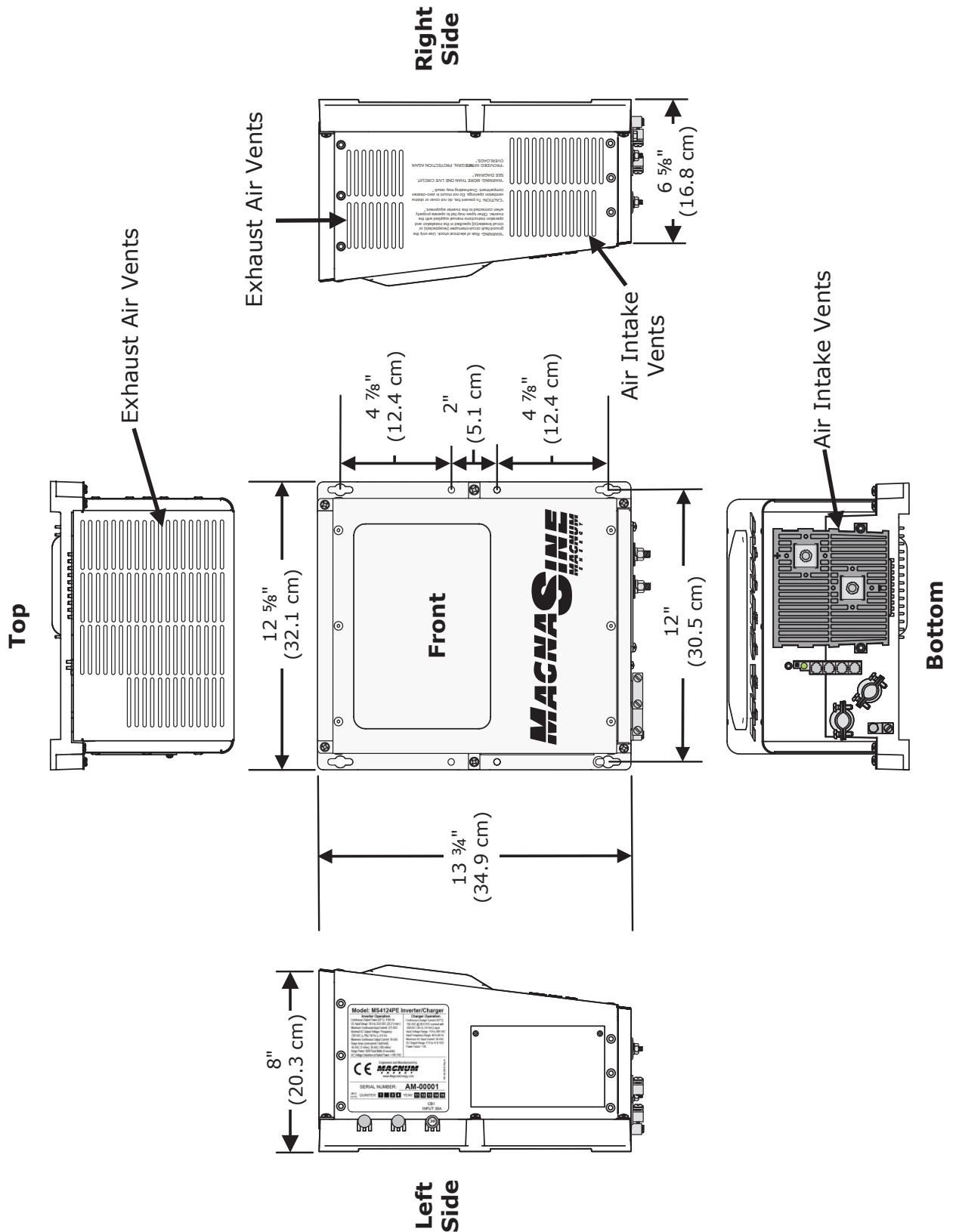

Figure 2-3, MS-PE Series Dimensions and Side Reference

Installation

2.3 Wiring the Inverter – General Requirements

This section describes the requirements and recommendations for wiring the MS-PE Series inverter/charger. Before wiring the MS-PE Series inverter/charger, read all instructions.

All wiring should meet all local codes and industry standards, and be performed by qualified personnel such as a licensed electrician.



Info: This document uses the term “ground”, or “grounding”; the European equivalent is “earth”, or “earthing”. Refer to Appendix A-3 for equivalent AC/DC wiring terminology.

Inverter/charger systems involve power from multiple sources (e.g., inverter, generator, utility, batteries, solar arrays, etc.) which makes the wiring more hazardous and challenging.

The input and output AC and DC circuits are isolated from the inverter chassis. The inverter system grounding is the responsibility of the installer in accordance with local codes and standard safety practices.



WARNING: Ensure all sources of DC power (e.g., batteries, solar, wind, or hydro) and AC power (utility power or AC generator) are de-energized (i.e., breakers opened, fuses removed) before proceeding—to prevent accidental shock.

2.3.1 Protecting Wire – Conduit Box or Inverter Enclosure

The AC and DC wires into and out of the inverter must be protected as required by code. This can be done by using jacketed wires or by feeding the wires through conduit. To this end, Magnum offers DC conduit boxes (ME-CB or MPX-CB) and single (MMP-E Series) or multiple (MP-E Series) inverter enclosures. The enclosures include the necessary AC and DC inverter breakers that allow both the AC and DC conduit to be connected to the inverter.



Info: Remove the strain reliefs and replace with 3/4” grommets if using the ME-CB or MPX-CB conduit boxes, MS-CEFB filter box, or either Magnum enclosure system.

2.3.2 Wiring Requirements

- All conductors that are at risk for physical damage must be protected by conduit, tape, or placed in a raceway.
- Always check for existing electrical, plumbing, or other areas of potential damage prior to making cuts in structural surfaces or walls.
- Do not mix AC and DC wiring in the same conduit or panel unless specifically approved/ designed for both AC and DC wiring. Where DC wiring must cross AC or vice-versa, try to make the wires at the crossing point perpendicular (90 degrees) to one another.
- Both AC and DC overcurrent protection **must** be provided as part of the installation.
- The inverter requires a reliable negative and ground return path directly to the battery.
- Use only copper wires with a minimum temperature rating of 75°C.

2.3.3 Wire Routing

Before connecting any wires, determine all wire routes to and from the inverter. Typical routing scenarios:

- AC input wiring from the main AC panel to the inverter
- AC input wiring from a generator (optional) to the inverter
- DC input wiring from the batteries to the inverter
- AC output wiring from the inverter to the AC sub-panel or to dedicated circuits
- Battery Temperature Sensor cable from the inverter to the batteries
- Remote control cable (optional) to the inverter
- Ground wiring to and from the inverter

2.3.4 Torque Requirements

- Torque all AC wiring connections to 1.8 N-m (16 in lbf). Torque DC cable connections from 13.6 to 16.3 N-m (10 to 12 ft lbf).

2.4 DC Wiring

This section describes the inverter's required DC wire sizes, the recommended disconnect/overcurrent protection, and how to make the DC connections to the inverter and the battery bank. Refer to Figure 2-4 when connecting the DC wires.



WARNING: Even though DC voltage is “low voltage”, significant hazards may be present, particularly from short circuits of the battery system.



CAUTION: The inverter is NOT reverse polarity protected—which means that if the negative and positive battery voltage is connected backwards to the inverter, the inverter will likely be damaged. You should verify the correct voltage polarity using a voltmeter BEFORE connecting the DC wires.



CAUTION: Before wiring the DC cables, review the safety information at the beginning of this manual and the instructions below to ensure a safe and long-lived system.



Info: DO NOT connect the battery cables to the inverter until all wiring is complete and the correct DC voltage and polarity have been verified.

- When the inverter is installed in a photovoltaic system, standard safety practices require that the DC circuit conductors and overcurrent devices to the inverter be sized to carry not less than 125% of the inverter's maximum current rating.
- The DC positive and negative cables connected to the inverter from the battery bank should be tied together with wire ties or electrical tape approximately every 15.2 cm (6"). This helps improve the surge capability and reduces the effects of inductance, which improves the inverter waveform and reduces the wear of the inverter's filter capacitors.
- Use crimped and sealed copper ring terminal lugs to connect the DC wires to the inverter's DC terminals. (We use 5/16" terminal lugs here in U.S., determine the European equivalent.)
- The battery bank voltage **must** match the DC voltage required by the inverter (i.e., 24-volt battery bank for a 24-volt inverter), or the inverter may be damaged.
- To ensure the maximum performance from the inverter, all connections from the battery bank to the inverter should be minimized. The exceptions are the DC overcurrent disconnect in the positive line and a shunt in the negative line. Any other additional connection will contribute to additional voltage drops, and these extra connection points may loosen during use.
- All wiring to the battery terminals should be checked periodically (once a month) for proper tightness. The torque requirement for the DC terminals is between 13.6 to 16.3 N-m (10 to 12 ft lbf). If you do not have a torque wrench, ensure all DC terminals are tight and cannot move.
- Be aware that overtightening or misthreading the nuts on the DC terminals can cause the bolts to strip and snap/break off.
- Make sure cables have a smooth bend radius and do not become kinked. Place long cable runs in conduit and follow existing wire runs where possible.
- A brief spark or arc may occur when connecting the battery cables to the inverter DC terminals; this is normal and due to the inverter's internal capacitors being charged.
- Color code the DC cables/wires with colored tape or heat shrink tubing: BROWN for positive (+); BLUE for negative (-); and GREEN (or GREEN w/YELLOW stripe) for DC ground to avoid polarity problems. Refer to Table A-2 (in Appendix A-3) for a list of equivalent DC wiring color codes for Europe and U.S./Canada.

Installation

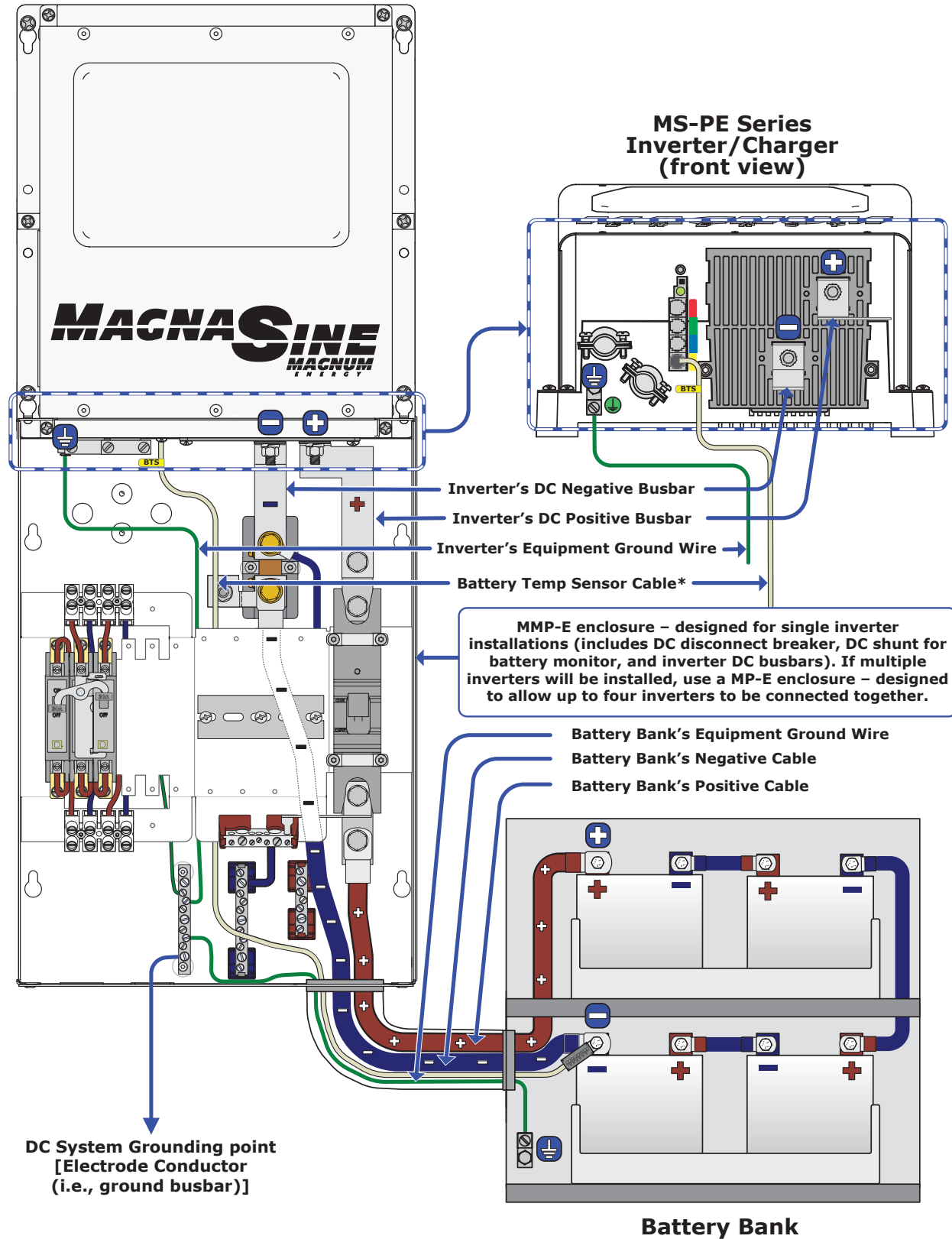

Figure 2-4, DC and Battery Temperature Sensor Wiring

2.4.1 DC Wire Sizing

It is important to use the correct sized DC wire to achieve maximum efficiency from the system and to reduce fire hazards associated with overheating. Always keep your wire runs as short as practical to prevent low voltage shutdowns and to keep the DC breaker from nuisance tripping (or open fuses) because of increased current draw. See Table 2-1 to select the minimum DC wire size (and corresponding overcurrent device) based on your inverter model. The cable sizes listed in Table 2-1 are required in order to reduce stress on the inverter, minimize voltage drops, increase system efficiency, and ensure the inverter’s ability to surge heavy loads.

If the distance from the inverter to the battery bank is greater than 1.5 m (5 ft), the DC wire will need to be increased. Longer distances cause an increase in resistance, which affects the performance of the inverter. Use the overcurrent device as previously identified from Table 2-1, and then refer to Table 2-2 to determine the minimum DC wire size needed for various distances (based on your inverter model).

2.4.2 DC Overcurrent Protection

DC overcurrent protection is not included in the inverter—for safety reasons and to comply with electrical code regulations—it must be provided as part of the installation. The DC overcurrent protection device must be installed in the positive DC cable line—it can be a fuse or a circuit breaker—and must be DC rated. It must be correctly sized according to the size of the DC cables being used, which means it is required to open before the cable reaches its maximum current carrying capability, thereby preventing a fire. In a residential or commercial electrical installation, standard safety practices require both overcurrent protection and a disconnect switch. If a circuit breaker is used as the overcurrent protection device, it can also be used as the required DC disconnect.

If a fuse is used as an overcurrent device, a Class-T type or equivalent is recommended. This fuse type is rated for DC operation, can handle high short-circuit currents, and has a time delay that allows for momentary current surges from the inverter without opening the fuse. However, because the fuse can be energized from both directions, standard safety practices require that the power be disconnected on both ends of the fuse before servicing.

Use Table 2-1 to select the DC overcurrent device needed based on the recommended minimum wire size for your particular inverter model (may not meet all local code or industry standard requirements).

Table 2-1, Recommended DC Wire/Overcurrent Device for Rated Use

Inverter Model	Maximum Continuous Current ¹	Using Conduit		In Free Air		DC Grounding Electrode Wire Size ⁴
		Minimum DC Wire Size (rating) ²	Recomm. DC Breaker Size ³	Minimum DC Wire Size (rating) ²	Maximum DC Fuse Size ³	
MS4124PE	273 amps	107.2 mm ² (#4/0 AWG) 260 amps	250 amps ⁵	67.4 mm ² (#2/0 AWG) 300 amps	300 amps with time delay	13.3 mm ² (#6 AWG)
MS4348PE	143 amps	67.4 mm ² (#2/0 AWG) 195 amps	175 amps	33.6 mm ² (#2 AWG) 190 amps	175 amps with time delay	13.3 mm ² (#6 AWG)

Note¹ – Maximum continuous current is based on the inverter’s continuous power rating at the lowest input voltage with an inverter inefficiency factored in.

Note² – Copper wire rated with 90°C (194°F) insulation at an ambient temperature of 30°C (86°F), with a multiple cable fill factor (0.8) de-rating (if needed).

Note³ – The next larger standard size overcurrent device may be used if the de-rated cable ampacity falls between the standard recommended overcurrent devices.

Note⁴ – As recommended, the DC grounding electrode conductor can be a 13.3 mm² (#6 AWG) conductor if that is the only connection to the grounding electrode and that grounding electrode is a rod, pipe, or plate electrode.

Note⁵ – May not allow continuous operation at full rated power.

Installation

Table 2-2, DC Wire Size For Increased Distance

Inverter Model	Minimum Recommended DC Wire Size (one way) *					
	1.5 m (5 ft) or less		1.5-3 m (5-10 ft)		3-4.5 m (10-15 ft)	
	In Conduit	In free air	In Conduit	In free air	In Conduit	In free air
MS4124PE	107.2 mm ² (#4/0 AWG)	67.4 mm ² (#2/0 AWG)	107.2 mm ² x2 (#4/0 AWG x2)	107.2 mm ² (#4/0 AWG)	not recommended	107.2 mm ² x2 (#4/0 AWG x2)
MS4348PE	67.4 mm ² (#2/0 AWG)	33.6 mm ² (#2 AWG)	107.2 mm ² (#4/0 AWG)	42.4 mm ² (#1 AWG)	107.2 mm ² x2 #4/0 AWG x2	53.5 mm ² #1/0 AWG

* Copper wire rated with 90°C (194°F) insulation at an ambient temperature of 30°C (86°F).

2.4.3 DC Cable Connections

Do not put anything between the battery cable ring lug and the battery post or the flat metal part of the inverter’s DC terminal. When connecting the battery cable to the battery post or inverter DC terminal, the cable should be placed directly against the inverter DC terminal or battery post. Incorrectly installed hardware causes a high resistance connection, which could lead to poor inverter/charger performance and may melt the cable and terminal connections.

Refer to Figures 2-5 and 2-6 to connect the DC cables and to stack the hardware correctly. Tighten the terminal connections from 13.6 to 16.3 N-m (10 to 12 ft lbf).



CAUTION: The DC terminal and Flange/Keyp nuts are made of stainless steel, which has a high likelihood of seizure. To help prevent the bolt and nut from seizing—causing the bolts to strip or snap/break-off—the use of anti-seize lubricant is highly recommended.



Info: If antioxidant grease or spray is used, apply it after all the connections have been made and are properly tightened.



Info: A 1/2-inch wrench or socket is used to tighten the 5/16 SAE Keyp nuts.

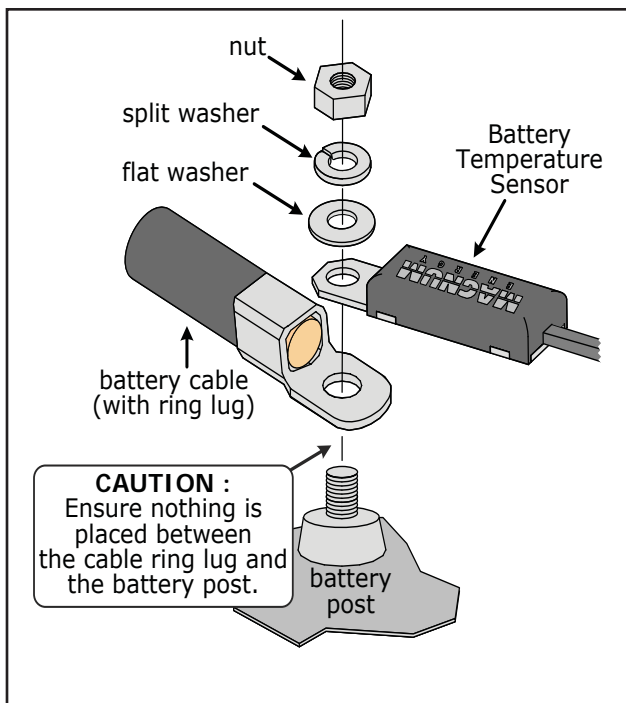

Figure 2-5, Battery Hardware Installation

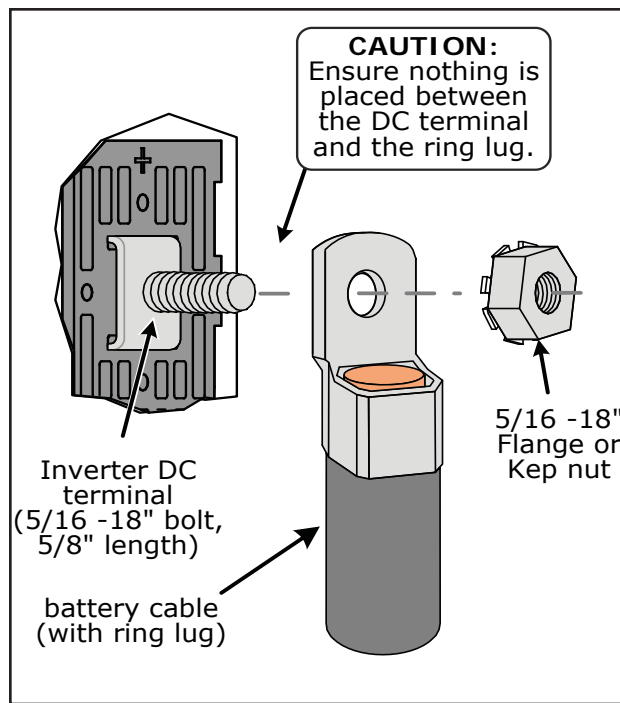

Figure 2-6, Inverter DC Hardware Installation

2.4.4 Wiring the Battery Bank



WARNING: Lethal currents will be present if the positive and negative cables attached to the battery bank touch each other. During the installation and wiring process, ensure the cable ends are insulated or covered to prevent touching/shorting the cables.



Info: DO NOT connect the DC wires from the battery bank to the inverter until: 1) all DC and AC wiring are completed, 2) the correct DC and AC overcurrent protection have been installed, and 3) the correct DC voltage and polarity have been verified.



Info: For the MS-PE Series inverter/charger to perform optimally, a minimum battery bank of 200 Ahr is recommended for moderate loads (<1000W) and greater than 400 Ahr for heavy loads (≥1000W).

Depending upon the voltage of the batteries you use in the installation (6 or 12 VDC), the batteries must be wired in series, parallel, or series-parallel to provide the correct voltage (see Appendix B – Battery Information for guidance on wiring batteries together). The interconnecting DC wires must be sized and rated exactly the same as those used between the battery bank and the inverter. Place the batteries as close as practical to the inverter, preferably in an insulated and ventilated enclosure. Allow adequate space above the batteries to access the terminals and vent caps (as applicable). Also, allow at least 2.5 cm (1”) of space between the batteries to provide good air flow. DO NOT mount the batteries directly under the inverter.



CAUTION: Install batteries in a well ventilated area as they can produce explosive gases. For compartment/enclosure installations, always vent batteries to the outside.



Info: To ensure the best performance from your inverter system, batteries should be of the same size, type, rating, and age. Do not use old or untested batteries.

2.4.5 Battery Temperature Sensor Installation and Wiring

The Battery Temperature Sensor (see Figure 2-7) provides the inverter with precise battery temperature information to automatically adjust the Absorb and Float charge voltage set-points. This allows the batteries to be correctly charged under extreme temperature changes.

If the temperature sensor is NOT installed and the batteries are subjected to large temperature changes, the battery life may be shortened.

The BTS cable may be extended—using a RJ11 connector (female to female) and a standard phone cable with RJ11 connectors—to a maximum length of 12m (40’). However, your inverter to battery cable length shouldn’t exceed the recommended distance shown in Table 2-2.

To install the BTS:

1. Attach the ring terminal end of the battery temperature sensor to the negative battery terminal; see Figure 2-5 for proper connection to the battery terminal.
2. Route the sensor’s cable to the inverter following existing wire runs.
3. Connect the RJ11 connector end of the BTS cable to the yellow-labeled BTS port on the inverter (see Figure 1-1, Item 6).

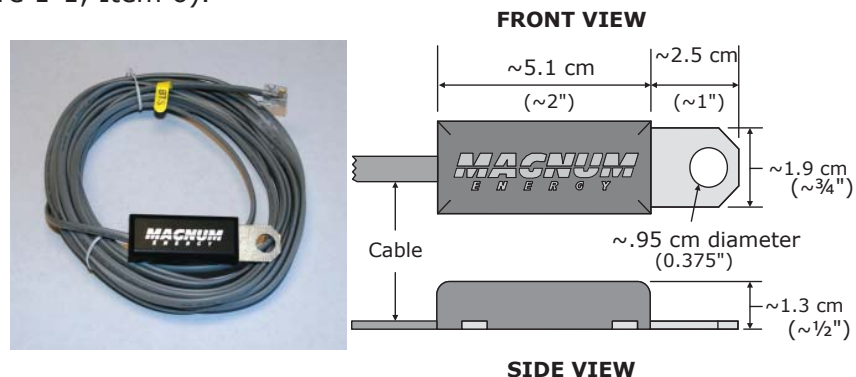

Figure 2-7, Battery Temperature Sensor

Installation

2.4.6 Wiring the Inverter to the Battery Bank



CAUTION: The inverter is NOT reverse polarity protected—if this happens the inverter will be damaged and will not be covered under warranty. Before connecting the DC wires from the batteries to the inverter, verify the correct battery voltage and polarity using a voltmeter. If the positive terminal of the battery is connected to the negative terminal of the inverter and vice versa, severe damage will result. If necessary, color code the cables (with colored tape); brown for positive (+) and blue for negative (-) to avoid polarity confusion.



Info: The DC overcurrent device (i.e., circuit breaker or fuse) must be placed in the positive (brown) DC cable line between the inverter's positive DC terminal and the battery's positive terminal (brown); as close to the battery as possible.

DC Ground Wire

Route an appropriately sized DC grounding wire (green, green w/yellow stripe, or bare wire) from the inverter's DC equipment ground terminal (Item 7, Figure 1-2) to a dedicated system ground. Recommended tightening torque is 5.1 N-m (45 in lbf). Refer to Section 2.6 for grounding information and sizing the DC ground wires.

DC Negative Wire

Route an appropriately sized DC negative wire (marked blue) from the negative terminal of the battery bank to the inverter's negative DC terminal (Item 11, Figure 1-2).



Info: If installing a battery monitor such as Magnum's ME-BMK, install a DC shunt in-line with the negative battery cable.

DC Positive Wire

Mount the circuit breaker or fuse assembly as near as practical to the batteries and leave open (i.e., no power to inverter).



WARNING: DO NOT close the DC circuit breaker or connect the fuse to connect battery power to the inverter at this time. This will occur in the **Functional Test** after the installation is complete.



CAUTION: If connecting live battery cables to the inverter's DC terminals, a brief spark or arc may occur; this is normal and due to the inverter's internal capacitors being charged.

1. Route and connect an appropriately sized DC positive wire (brown) from the inverter's positive DC terminal (Item 10, Figure 1-2) to one end of the circuit breaker (or DC fuse block).
2. Connect a short wire (same rating as the DC wires) to the other side of the DC circuit breaker (or one end of the fuse/disconnect assembly), and the other end of the short wire to the positive terminal of the battery bank (see Figure 2-1 for reference). This is essential to ensure even charging and discharging across the entire battery bank.
3. Ensure the DC wire connections (on the batteries, inverter, and DC circuit breaker/fuse lugs) are flush on the surface of the DC terminals, and the hardware (lock washer and nut) used to hold these connections are stacked correctly (Figures 2-5 and 2-6).
4. Verify all DC connections are torqued from 13.6 to 16.3 N-m (10 to 12 ft lbf).
5. Once the DC connections are completely wired and tested, coat the terminals with an approved anti-oxidizing spray.
6. Attach the red and black terminal covers over the inverter's DC connectors, and then secure them in place with the supplied screws.

If the batteries are in an enclosure, perform a final check of the connections to the battery terminals, and then close and secure the battery enclosure.

2.5 AC Wiring

This section provides information on how to make the AC connections to the inverter using the correct AC wire size and corresponding overcurrent protection.

2.5.1 Pre-AC Wiring Requirements



CAUTION: Before installing any AC wiring, review the safety information at the beginning of this manual and the following to ensure a safe and long-lived system:

- Always use properly rated circuit breakers. If using an electrical sub-panel, circuit breakers can be moved from the main electrical panel to the sub-panel only if the breakers are also listed to be installed in the sub-panel.
- AC wiring must be no less than 5.3 mm² (#10 AWG) gauge copper wire and be approved for the application (i.e., residential, RV, or marine wiring).
- DO NOT connect the inverter's output to an AC power source. This could cause severe damage to the inverter and is not covered under warranty.
- The AC wire sizes recommended in this manual are based on the ampacities for copper wire rated with 75°C (167°F) insulation at an ambient temperature of 30°C (86°F).



WARNING: To reduce the risk of fire, do not connect this inverter to an AC load center (circuit breaker panel) having multi-wire branch circuits connected.

2.5.2 AC Wire Size and Overcurrent Protection

The AC input and output wiring must be sized per the local electrical safety code requirements to ensure the wire's ability to safely handle the inverter's maximum load current. The AC wiring must be protected from short circuits and overloads by an overcurrent protection device and have a means to disconnect the AC circuits. AC overcurrent protection is not included in the inverter and must be provided as part of the inverter installation. The AC overcurrent protection device must be a circuit breaker or a fuse/disconnect and be properly sized and branch circuit rated for the wire it is protecting and the appliances being powered.



Info: When wiring the AC input and output circuits, we highly recommend a full system Inverter Bypass Switch. This simple item provides a convenient way to isolate the inverter for battery maintenance, and it could save you hours of downtime—if you ever need to service your inverter—by enabling you to continue to power your AC loads without any re-wiring. Because we think it is an essential part of an inverter system, every Magnum panel (MMP-E/MP-E Series) is equipped with an inverter bypass switch.

When in Standby mode, the full AC continuous pass-thru capacity of the MS-PE Series inverter/charger is 30 amps. For a 30-amp continuous pass-thru capability, the AC HOT IN input to the inverter requires a 30-amp continuous duty rated breaker¹, which corresponds to a minimum cable size of 5.3 mm² (#10 AWG²) in conduit. If you are using other circuit breakers/wire sizes, refer to the appropriate local electrical codes and standards for proper sizing requirements.



CAUTION: The inverter's internal AC transfer relay contacts are rated for 30 amps, the pass-thru current must be no greater than 30 amps or damage to this relay may occur.

Note¹ – The breaker must be de-rated by 80% if not rated for continuous duty. Standard safety practices require that circuits are not to be operated continuously at more than 80% of rating unless listed with a 100% continuous rating.

Note² – Copper wire rated with 75°C insulation at an ambient temperature of 30°C (86°F).

Installation

2.5.3 AC Terminal Block Connections

The inverter has a four-pole AC terminal block and one AC ground terminal to connect the inverter's AC input and output wiring. This terminal block allows either a service/distribution panel (main panel) or a generator to be wired to the inverter's input, and then to a dedicated panel (sub-panel) between the inverter's output wiring and the AC loads. To access and view the AC terminal block and ground terminal, remove the two Phillips screws holding the AC access cover plate (see Figure 1-3, Item 15). Each connection on the AC terminal block is rated to accept one 2.1 to 13.3 mm² (#14 to #6 AWG) CU stranded wire, or two 3.3 mm² (#12 AWG) CU stranded wires. Each connection uses a M3.5 slotted head screw, and the maximum tightening torque is 1.8 N-m (16 lbf-in).



Info: For marine installations and to comply with standard safety requirements, the four-pole AC terminal is provided with a stainless steel wire protector to prevent wire damage from the set-screw.



Info: The inverter's NEUT IN and NEUT OUT terminals are electrically isolated from each other while inverting. This is related to the neutral-ground bonding requirement and helps to prevent ground-loops (see Section 2.6.5 for more information). If the installation requires the input and output neutrals to be connected together, the inverter's neutral-to-ground connection must be disconnected (see Section 2.6.6).

The AC ground terminal can accept one 2.1 to 13.3 mm² (#14 to #6 AWG) CU stranded wire. It uses a slotted head screw and has a recommended maximum tightening torque of 5.1 N-m (45 in lbf). For multiple ground wires, use a pressure or mechanical connector to attach the single wire from the AC ground terminal to the input and output ground connections.

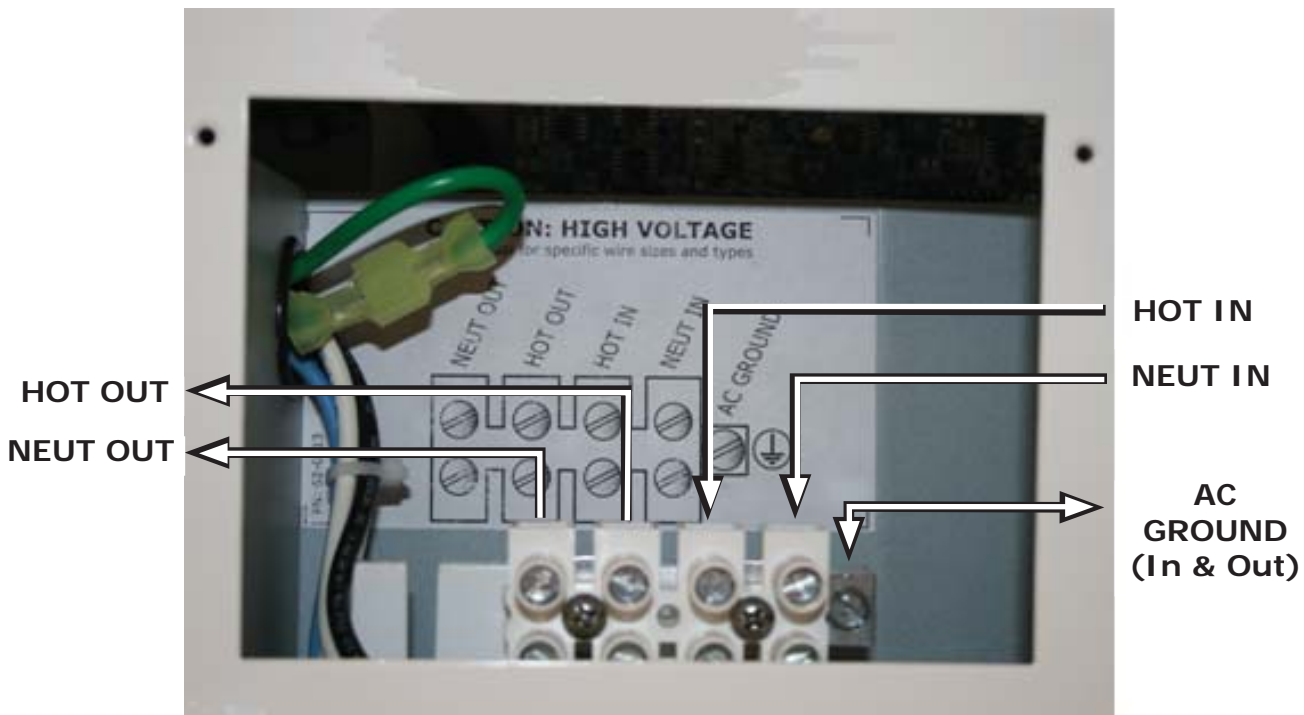

Figure 2-8, AC Terminal Block

2.5.4 AC Conductor Wiring

The following steps are basic guidelines for installing and connecting the AC wiring into and out of the inverter.



WARNING: Before making any AC connections, make sure the inverter is disconnected from the battery and there is no other source of live power connected to the inverter.

Remove the two Phillips screws on the AC wiring access cover (see Figure 1-3, Item 15) to access the internal AC terminal block (see Figure 2-8).

Wiring the Inverter AC Input

1. Route the wires (HOT1, NEUTRAL1, and GROUND1) from the AC electrical main panel through one of the strain relief clamps on the inverter (Figure 1-2, Item 8). Tighten the strain relief clamp securely on the cables. Always leave a little extra slack in the wiring. Refer to Figure 2-9.
2. Connect the HOT1 wire (brown) from the main panel's dedicated breaker to the inverter's HOT IN terminal. **Note:** *Do not tighten wires until after the AC wiring inspection below.*
3. Connect the NEUTRAL1 wire (blue) from the main panel's neutral busbar to the inverter's NEUT IN terminal.

Wiring the Inverter AC Output

1. Route the wires (HOT2, NEUTRAL2, GROUND2) from the AC electrical sub-panel through the unused strain relief clamp on the inverter (Figure 1-2, Item 8). Tighten the strain relief clamp securely on the cables. Leave a little extra slack in the wiring.
2. Connect the HOT2 wire (brown) from the sub-panel's main breaker to the inverter's HOT OUT terminal.
3. Connect the NEUTRAL2 wire (blue) from the sub-panel's neutral busbar to the inverter's NEUT OUT terminal.

Combining the AC Grounds

1. Combine the GROUND1 wire (green w/yellow stripe) from the main panel's ground busbar and the GROUND2 wire (green w/yellow stripe) wire from the sub-panel's ground busbar. After these grounds are combined, connect them to the inverter's AC GROUND terminal.

AC Wiring Inspection

1. Verify all cable runs are secured. If installed in a mobile installation, use wire ties or other non-conductive fasteners to prevent chafing or damage from movement and vibration.
2. Verify strain reliefs or grommets are in place to prevent damage to the wiring or conduit where it passes through walls/bulkheads or other openings.
3. After verifying all AC connections are correct, torque all inverter AC terminal screws to 1.8 N-m (16 in lbf), and then torque the inverter's ground terminal screw to 5.1 N-m (45 in lbf).
4. Replace the AC wiring access cover and the covers on the electrical/distribution panels.

2.5.5 AC Wiring Configuration

The wiring configuration for installing and connecting the AC conductors into and out of the inverters (MS4124PE & MS4348PE models) requires an AC source¹ of 230VAC @ ≤ 30 amps. The maximum input breaker required is 30A (single pole), and the minimum wire size is 5.3 mm²/#10 AWG (In & Out). Refer to the wiring diagram in Figure 2-9.

Note¹ – AC Source is from either the utility/grid power (i.e., shorepower) or an AC generator.

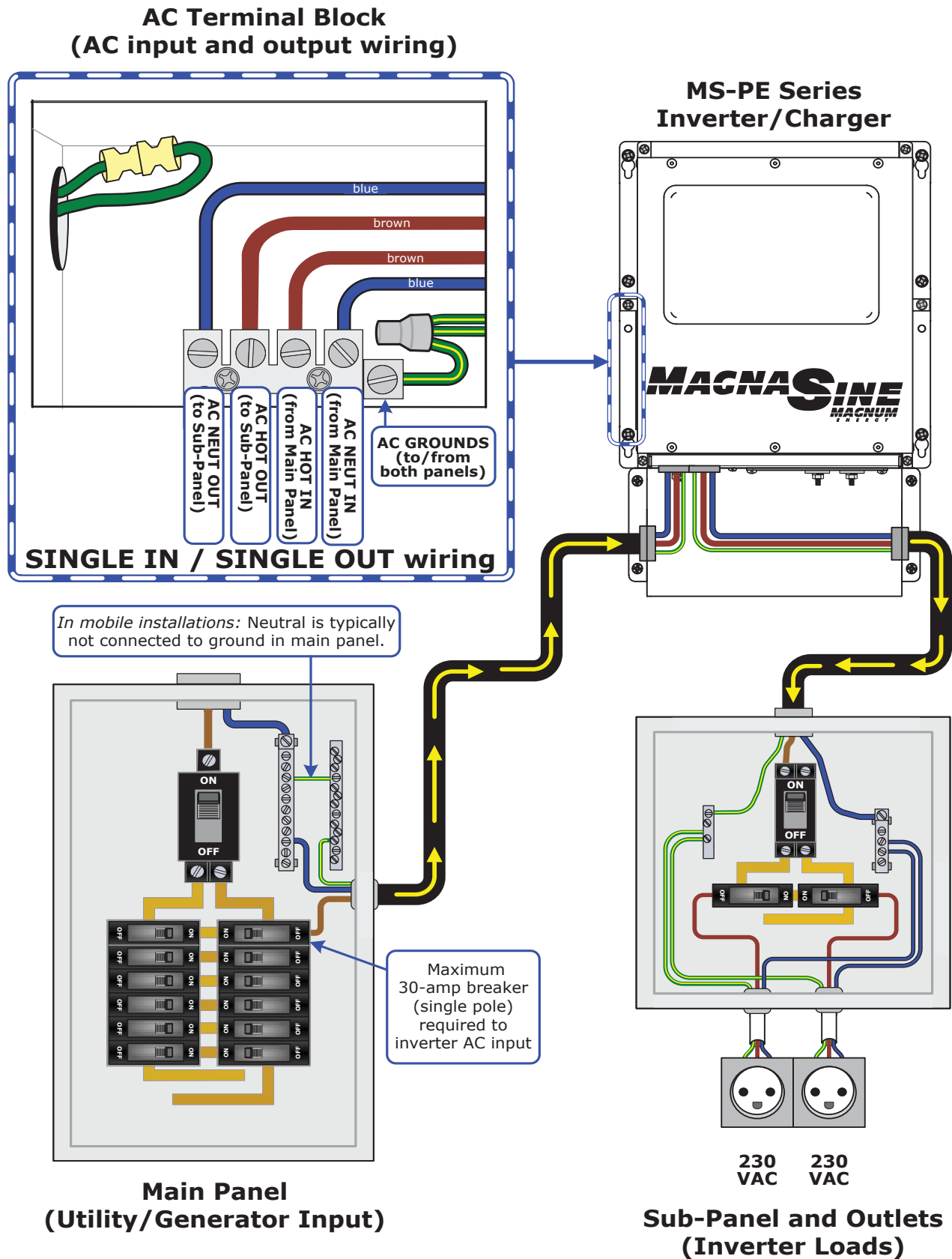

Figure 2-9, AC Wiring Input/Output

2.6 Grounding Inverters

The inverter/charger should always be properly connected to a permanent, grounded wiring system. A properly grounded system limits the risk of electrical shock, reduces radio frequency noise from the inverter, and minimizes excessive surge voltages induced by lightning. Ensure there is a well-defined, low-resistance path from the electrical system to the grounding system. The low-resistance path helps stabilize the electrical system voltage with respect to ground and carries fault currents directly to ground if the electrical system malfunctions. Review the following terms to understand how the conductors in the electrical circuit connect to the system ground:

- **Grounded Conductor (GC):** The wire/cable in the electrical system that normally carries current (usually AC neutral and/or DC negative), and is intentionally connected or “bonded” to the ground system. This wire, or the ends of this wire, should be colored blue.
- **Equipment Grounding Conductor (EGC):** A wire/cable that does not normally carry current and is used to connect the exposed metal parts of equipment—that might be accidentally energized—to the grounding electrode system or to the grounded conductor. This wire, or the ends of this wire, should be green or green w/yellow stripe; or this wire can be bare copper.
- **Grounding Electrode Conductor (GEC):** The wire/cable that does not normally carry current and connects the grounded conductor and/or the equipment grounding conductor to the grounding electrode at the service equipment.
- **Grounding Electrode (GE):** A ground rod or conducting element that establishes an electrical connection to the earth.
- **System Bonding Jumper (SBJ):** The connection between the grounded circuit conductor in the electrical system and the equipment grounding conductor at a separately derived system.

The MS-PE Series inverter/charger uses both AC and DC power; however, the AC electrical system is isolated from the DC electrical system by an internal transformer. Although this inverter/charger has two electrical systems, each electrical system must be properly grounded and connected to a common earth reference (refer to Figure 2-10).

For proper grounding, each electrical system must connect all exposed metal parts of equipment (via EGC) and one of the current carrying conductors (GC) together at a common point (ground busbar – GBB), usually by a system bonding jumper (SBJ) in an electrical service disconnect panel. The common point of each electrical system is then connected (via GEC) to the common ground reference, such as a ground rod (GE). This connection to earth should only be made at one point in each electrical system; otherwise, parallel paths will exist for the currents to flow. These parallel current paths would represent a safety hazard and are to be avoided during installation.

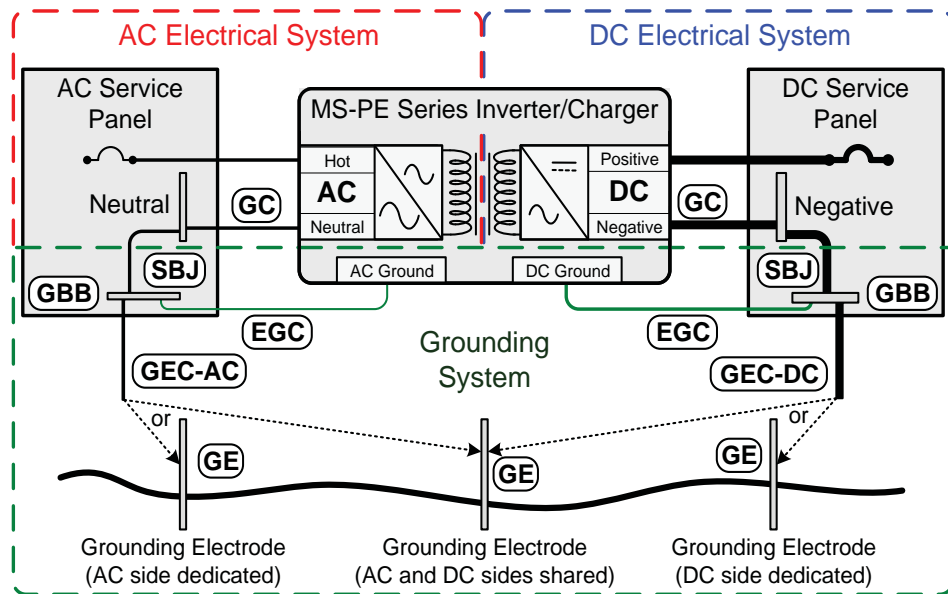

Figure 2-10, Grounding System for MS-PE Series

Installation

2.6.1 Sizing the Grounding Electrode Conductors

AC Side – The size of the AC grounding electrode conductor (GEC-AC) depends on the size of the largest ungrounded conductor feeding the AC load center. One 8.4 mm² (#8 AWG) copper conductor will serve as an AC grounding electrode conductor (GEC-AC) for AC power conductors smaller than and including 33.6 mm² (#2 AWG) copper. See Table 2-3 for additional values.

Table 2-3, AC Grounding Electrode Conductor Sizing

Size of Largest Ungrounded Conductor	Minimum Size of Grounding Electrode Conductor
33.6 mm ² (#2 AWG) or smaller	8.4 mm ² (#8 AWG)
42.4 to 53.5 mm ² (#1 to #1/0 AWG)	13.3 mm ² (#6 AWG)
67.4 or 85.0 mm ² (#2/0 or #3/0 AWG)	21.1 mm ² (#4 AWG)
85.0 mm ² (Over #3/0 AWG) thru 350 kcmil	33.6 mm ² (#2 AWG)

DC Side – To size the DC grounding electrode conductor (GEC-DC), you must first determine which one of the following three methods will be used to connect the DC and AC grounding points in the inverter's two electrical systems to the common earth ground:

- Method 1 (Figure 2-11):** This method uses a separate grounding electrode for the DC system and the AC system. In this method—since there are multiple connections to the DC grounding electrode (GE-DC)—the size of the DC grounding electrode conductor (GEC-DC) cannot be smaller than the largest conductor in the DC system (usually the battery-to-inverter cable). The DC grounding electrode (GE-DC) must be bonded to the AC grounding electrode (GE-AC) to establish a grounding system; this bonding conductor (BC) cannot be smaller than the largest grounding electrode conductor (GEC), either AC or DC.

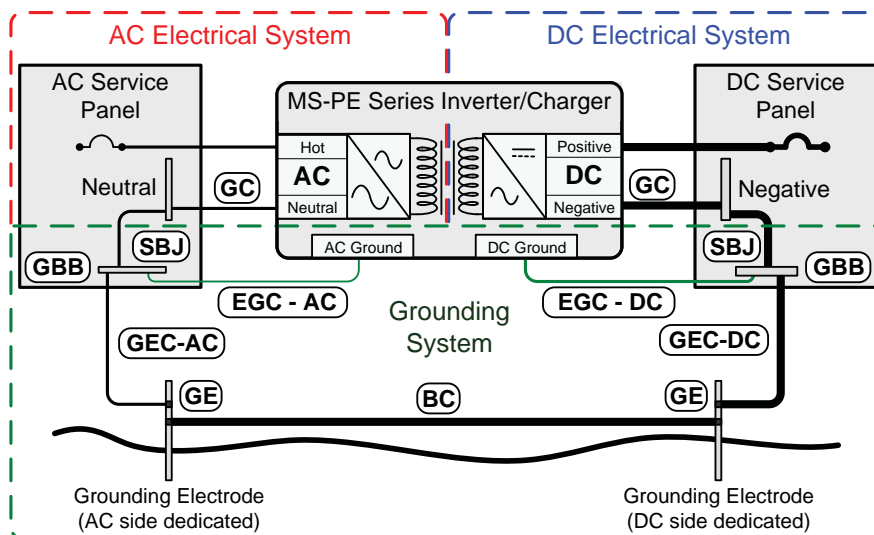

Figure 2-11, Multiple Connections to DC Ground Rod (Method 1)

- Method 2 (Figure 2-12):** When the AC and DC service panels are near each other, the AC grounding electrode conductor (GEC-AC) and the DC grounding electrode conductor (GEC-DC) can be connected to a single grounding electrode (GE). In this method—since there are multiple connections to the DC grounding electrode (GE-DC)—the size of the DC grounding electrode conductor (GEC-DC) cannot be smaller than the largest conductor in the DC system (usually the battery-to-inverter cable).

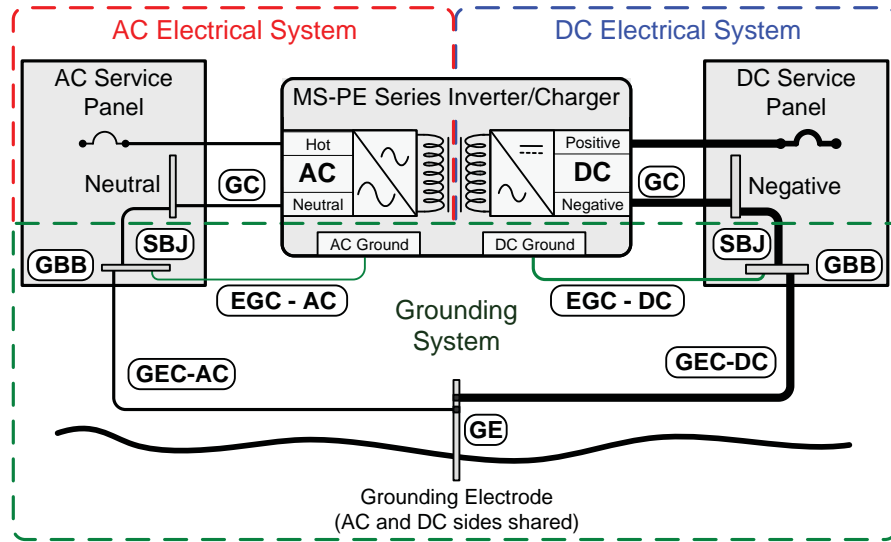

Figure 2-12, Multiple Connections to DC Ground Rod (Method 2)

- Method 3 (Figure 2-13):** The AC grounding electrode conductor (GEC-AC) is bonded to the DC ground point and the DC grounding electrode conductor (GEC-DC) is the *only connection* to the grounding electrode (GE), which must be a rod, pipe, or plate electrode. In this method, since there is only one connection to the ground rod, the DC grounding electrode conductor (GEC-DC) is not required to be larger than 13.3 mm² (#6 AWG) copper. The reasoning for allowing this smaller grounding electrode conductor is that it is only required to stabilize the system voltage with respect to earth, and the other properly sized conductors in each electrical system will safely carry any fault currents if they occur.

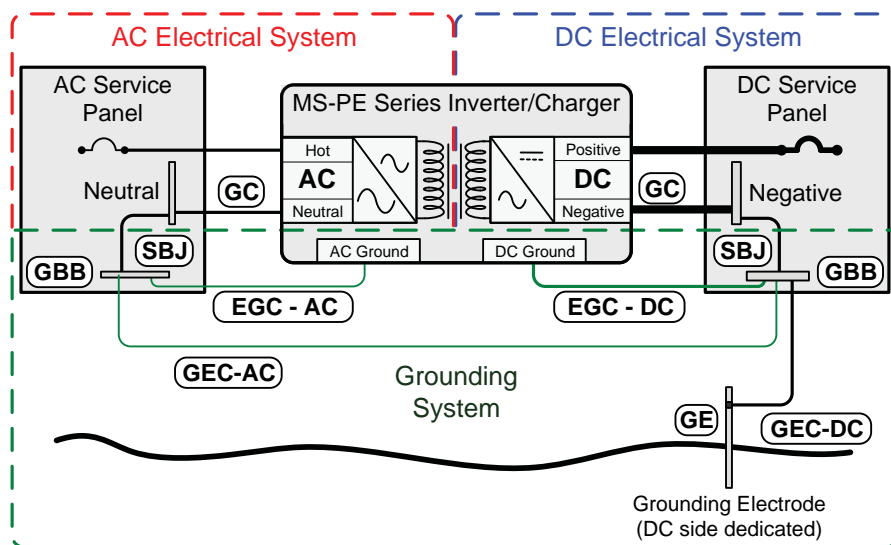

Figure 2-13, Single Connection to DC Ground Rod (Method 3)

Installation

2.6.2 System Bonding Jumper

The MS-PE Series inverter does not include an internal bond between the grounded conductor (AC neutral/DC negative) and the equipment grounding terminals. This bond [system bonding jumper (SBJ)] is usually done in the main distribution panel for each electrical system.



CAUTION: There should be one and only one point in each electrical system (both AC and DC) where the grounded conductor is attached to the grounding electrode conductor.

AC Side – The size of the system bonding jumper (SBJ) in the AC electrical system is based on the size of the largest AC ungrounded conductor. In accordance with standard practices, use Table 2-4 to determine the system bonding jumper size compared to the largest AC ungrounded conductor.

DC Side – The size of the system bonding jumper (SBJ) in the DC electrical system must not be smaller than the DC grounding electrode conductor (GEC-DC) used, which is determined by the grounding method that is used (see Section 2.6.1).

2.6.3 Equipment Grounding Conductor

The inverter case and all other noncurrent-carrying exposed metal surfaces in the entire electrical system that may be accidentally energized must be grounded. The equipment grounding conductor must be sized to safely carry the maximum ground-fault current likely to be imposed on it from where a ground-fault may occur. In accordance with standard practices, use Table 2-4 to size the equipment grounding conductors. This table requires that the equipment grounding conductor be sized according to the rating of the overcurrent device protecting the circuit.



CAUTION: The connections and wiring for the equipment grounding conductor must be continuous to allow fault currents to properly operate overcurrent devices. Whenever equipment is removed and it disconnects the bonding connection between the grounding electrode conductor and exposed conducting surfaces, a bonding jumper must be installed (while the equipment is being removed).

AC Side – Wherever the AC output from the inverter is connected to an AC load center, there should be an equipment grounding conductor connected between the inverter case and the grounding point in the AC load center. The AC equipment grounding conductor (EGC-AC) is sized per Table 2-4, and is connected to the inverter's AC equipment grounding terminal as shown in Figure 2-9.

DC Side – Since the currents on the DC side are higher than the AC side (10 times at 12 volts, 5 times at 24 volts, 2.5 times at 48 volts), the equipment grounding needs are different. The DC equipment grounding conductor (EGC-DC) is sized per Table 2-4, and connected to the DC equipment ground terminal on the inverter as shown in Figure 1-2 (Item 7).

Table 2-4, Equipment Grounding Conductor Sizing

Rating of Overcurrent Device	Minimum Size of Copper Ground Wire
15 amps	2.1 mm ² (#14 AWG)
20 amps	3.3 mm ² (#12 AWG)
30-60 amps	5.3 mm ² (#10 AWG)
100 amps	8.4 mm ² (#8 AWG)
200 amps	13.3 mm ² (#6 AWG)
300 amps	21.1 mm ² (#4 AWG)
400 amps	26.7 mm ² (#3 AWG)

2.6.4 Grounding on Boats

When installing the MS-PE Series inverter/charger on a boat, there are several considerations that must be followed when grounding to ensure a safe installation, prevent galvanic corrosion, and adhere to local codes and industry standards.

Ensure a Safe Ground Connection

When AC on the boat is being supplied by shorepower, the onboard neutral should be connected to safety ground on the dock. Consequently, neutral and safety ground should not be connected anywhere on the boat when shorepower is present. When AC on the boat is being supplied by the MS-PE Series inverter, the inverter's output neutral is connected to safety ground through an internal relay using its neutral-to-ground connection (see Figure 2-16).

The DC ground terminal on the MS-PE Series must also be connected to the boat's safety ground bus. This ensures that both the inverter's AC and DC ground terminals are connected to the boat's safety ground bus as a safety measure to provide protection against faults, and to provide a path for AC fault currents while the boat is connected to shorepower.

Preventing the Risk of Corrosion

The inverter's AC and DC ground terminals must be connected to the boat's safety ground to provide an important safety feature. However, this ground connection introduces the risk of galvanic corrosion and/or electrolysis of the boat's underwater metallic hardware.

Two possible solutions are typically used to maintain the correct onboard grounding requirements while greatly reducing (if not eliminating) the risk of galvanic corrosion. These solutions would be either using a galvanic isolator or an onboard isolation transformer.

Galvanic isolators allow high AC voltage faults to pass, but block low voltage corrosion/electrolysis currents from conducting.

Marine isolation transformers enable the shorepower to be connected to one side of the transformer while the boat's AC wiring system is connected to the other side. Since transformers do not allow DC currents to pass, the problem with galvanic corrosion is eliminated.

Recommended Inverter/Charger Grounding Requirements

- **DC Grounding Connections:**
 1. The DC grounding conductor (equipment ground) shall be:
 - a) Connected from the metallic case or chassis of the inverter/charger to the engine negative terminal or its bus;
 - b) and, an ampacity equal to that of the DC positive conductor (under certain conditions there may be an exception to allow this conductor to be one size smaller—refer to local standards).
 2. The inverter/charger's negative battery terminal and DC grounded conductor (negative cable) shall not be connected to the inverter case or chassis at the inverter/charger itself.
- **AC Grounding Connections:**
 1. The AC grounding conductor (green w/yellow stripe) shall be connected to the inverter/charger in a manner so that the AC ground connection will not be disconnected in servicing. This conductor is in addition to and independent of the DC grounding conductor.
 2. The neutral for AC power sources shall be grounded only at the following points:
 - a) The shorepower neutral is grounded only through the shorepower cable and not grounded on board the boat.
 - b) The inverter neutral shall be grounded at the inverter, and the output neutral shall be disconnected from ground when the inverter is operating in the charger/pass-through mode.
 - c) On systems using an isolation transformer or a polarization transformer, the inverter neutral (and the transformer secondary neutral) may be grounded at the AC main grounding bus instead of at the inverter.

Installation

2.6.5 Neutral to Safety Ground Bonding

The recommended standards for safely wiring residential, commercial, and mobile installations (e.g., caravans and boats) require that the neutral and safety ground be connected at the AC source; whether it is the utility feed in your home, an inverter, or a generator. This is to establish a specification that maximizes the possibility that a circuit breaker will activate if a hot-wire-to-ground fault occurs. These standards also require that the AC neutral be connected to safety ground (often called a “bond”) in one, and only one, place at any time. The single bond is established in order to make the electrical panel’s neutral line safe, by connecting it to ground. Without this bond, the neutral can have up to 230 VAC with respect to ground. On the other hand, if more than one bond is established, currents can circulate between neutral and ground and cause “ground-loop” currents. These ground-loops can trip residential current devices (RCDs), cause an electric shock hazard, and may be the reason for other annoying side effects.

In applications where you are using an inverter as one of your AC sources along with another AC source (e.g., utility power or generator), there is the potential of having multiple connections (bonds) between neutral and ground. Therefore, you must ensure that the inverter does not also connect the neutral-to-ground while the other AC source is actively powering the inverter loads. This can be prevented if your inverter is equipped with automatic neutral-to-ground switching.



WARNING: In most electrical systems, the neutral-to-ground bond is located in the main utility service entrance panel. Remove any bond downstream from the inverter to prevent multiple bonds. If there is an inverter sub-panel—separate from a main electrical panel—it should have a removable wire that allows the neutral bus to be unbonded from the ground busbar.

All MS-PE Series inverter/chargers have automatic neutral-to-ground switching to specifically work in multiple source applications. The MS-PE Series inverters use an internal relay that automatically connects the AC neutral output terminal to the vehicle/boat’s ground while inverting (Inverter mode) to provide the neutral-to-ground bond; as shown in Figure 2-14. However, when an external AC source (e.g., shorepower or a generator) is qualified, another neutral-to-ground connection is introduced in the system. When the MS-PE Series is connected to this external AC source and goes into Standby mode, the internal relay automatically opens the neutral-to-ground connection, as shown in Figure 2-15. This design keeps two neutral-to-ground connections from occurring at the same time, thereby preventing an electrical shock hazard between the vehicle/boat’s neutral and the external AC source’s neutral.

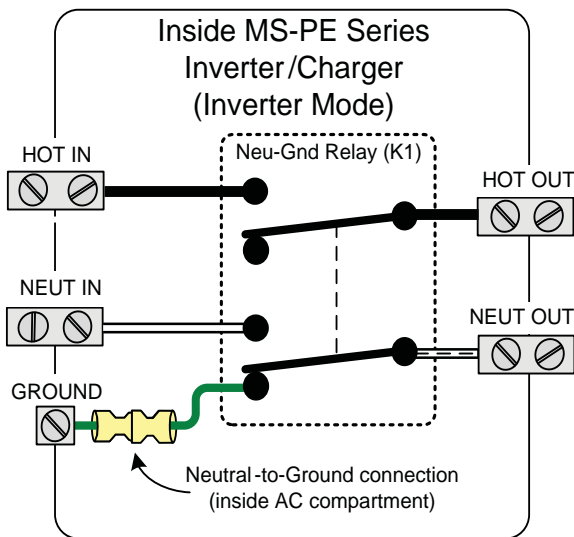

Figure 2-14, Neutral-to-Ground Connection (Inverter Mode)

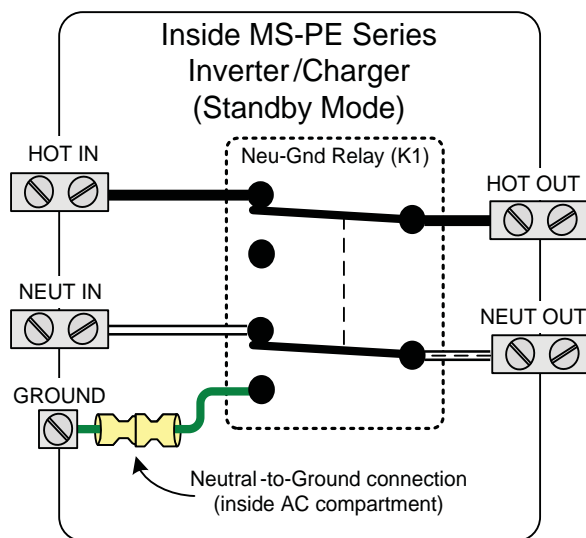

Figure 2-15, Neutral-to-Ground Connection (Standby Mode)

2.6.6 Disabling the Neutral-to-Ground Connection

All MS-PE Series inverter/chargers have the automatic neutral-to-ground switching feature. In some installations/jurisdictions, this feature must be disabled. If you are not sure whether you must disable this feature, check your local code requirements. The following steps will guide you in disabling the neutral-to-ground switching feature in the MS-PE Series inverter/charger.



Info: The ground connection from the inverter's AC and DC ground terminals should still be connected to the system ground even if ground switching has been disabled.



WARNING: Fire and Shock Hazard – disconnect all AC and DC sources before working in the AC wiring compartment.

1. Locate and remove the AC Access Cover plate (see Figure 1-3, Item 15) on the side of the MS-PE Series inverter.
2. Look inside and locate the green wire with the insulated connector at the top of the AC wiring compartment; see Figure 2-16. This insulated connector connects the neutral and ground inside the inverter.
3. Pull the two ends of the insulated connector apart to separate the green wire. This will prevent the neutral and ground from connecting inside this inverter.
4. Move the two disconnected ends away from each other and push back out of the way. You must ensure that the two connector ends will not have any contact with any other wires within the AC compartment. You may want to use electrical tape to insulate the ends and secure them out of the way.

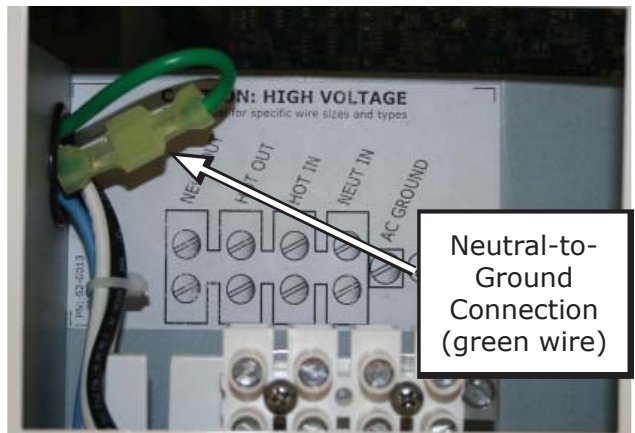

Figure 2-16, Disconnecting the Neutral-to-Ground Connection

2.6.7 Connecting a Large Ground Wire

If your installation requires a larger ground wire than what has been provided, follow the steps below to connect the larger wire.

1. Locate the DC Equipment Ground Terminal (see Figure 1-2, Item 7).
2. Locate and remove the AC Access Cover plate (see Figure 1-3, Item 15) on the side of the MS-PE inverter.
3. Within the AC wiring area, locate the hex nut on the back side of the DC ground terminal. After locating the hex nut, use a 7/16" wrench/nut driver to remove the hex nut, bolt, lock washer, and DC ground terminal, and then remove them from the chassis.
4. Reverse the removed bolt, and place it back in the chassis hole to attach a correctly sized ground cable to the MS-PE Series chassis, as shown in Figure 2-17.
5. Place the washer and nut on the bolt, over the ground cable, and securely tighten the nut [from 4 to 5 ft lbf (5.4 to 6.8 N-m)]. Replace AC Access Cover plate and secure.

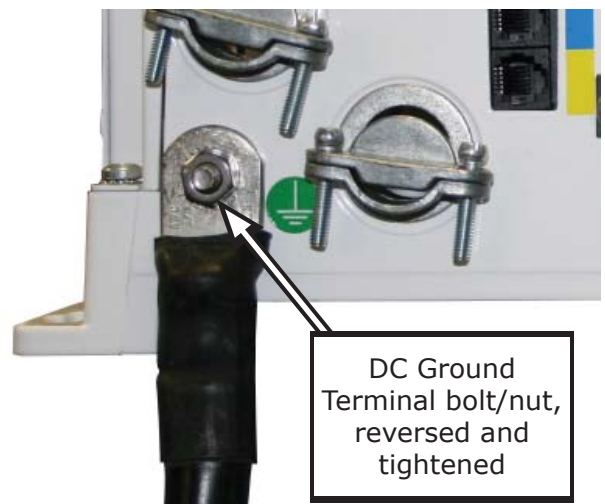

Figure 2-17, Large Ground Wire Connected to MS-PE Series

Installation

2.7 Inverter Notification Requirements

When an inverter is installed in a building, facility or structure, standard safety practices require a label or plaque be present. This label/plaque is required to be readily visible and provide information that informs personnel to the location of all electrical system disconnects. This is to ensure all power to a building is quickly located and shut down in an emergency. There are also specific requirements for this label/plaque depending on the inverter application, they are as follows:

- **Facilities with Standalone Systems** – Any building, facility, or structure with a photovoltaic power system that is not connected to a utility service source and is a standalone system, must have a permanent plaque or directory installed on the exterior of the building or structure at a readily visible location acceptable to the Authority Having Jurisdiction (AHJ). The plaque or directory must provide the location of system disconnecting means, and include information regarding whether the structure contains a standalone electrical power system.
- **Facilities with Utility Services and PV Systems** – Buildings, facilities, or structures with both utility service and a photovoltaic system must have a permanent plaque or directory providing the location of the service disconnecting means and the photovoltaic system disconnecting means, if they are not located at the same location.

2.7.1 Inverter Warning Label

A warning label as shown in Figure 2-18 is provided to inform all personnel that an inverter is installed in your electrical system. Affix this label in a clearly visible location at the electrical panel that is being powered by the inverter. This is because it might be falsely assumed that the panel is no longer “hot” after the AC power has been shut off, when power may actually still be available due to the inverter automatically powering the panel.

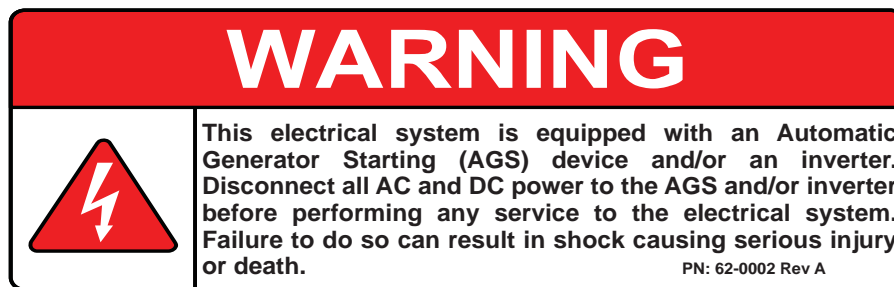

Figure 2-18, Warning Label

2.8 Final Inspection

1. Verify all cables/conduit runs are secured with wire ties or other non-conductive fasteners to prevent chafing or damage from movement and vibration.
2. Verify strain reliefs or grommets are in place to prevent damage to the wiring or conduit where it passes through walls, bulkheads, or other openings.
3. Verify all AC connections are correct and torqued to a maximum of 1.8 N-m (16 in lbf).
4. Replace the covers on the main electrical/distribution panel.
5. Replace the chassis access cover.
6. Verify the inverter’s front panel switch is in the OFF position.



Info: If required by code, have the installation inspected by an electrical inspector.

2.9 Functional Test

After all electrical connections to the inverter, batteries, AC source, and sub-panel have been completed; follow these steps to test the installation and the inverter's operation.



CAUTION: Use a multimeter to verify the correct DC voltage for your particular inverter model (i.e., 24-volt battery bank for a 24-volt inverter) and to ensure the polarity of the battery voltage is correct (battery positive connected to inverter positive terminal and battery negative connected to inverter negative terminal).

1. Apply battery power to the inverter by closing the DC circuit breaker. The inverter will remain off, but the green status indicator on the front of the inverter will quickly blink once to indicate that DC power has been connected and is ready to be turned on.
2. Prior to turning on the inverter, make sure all AC loads (e.g., appliances) are NOT connected to the inverter's output or to any AC outlets powered by the inverter.
3. Lightly press and release the inverter's ON/OFF switch to turn on the inverter. Verify the inverter's status indicator is blinking—indicating the inverter is on.
4. Connect a light bulb (10-25 watts) to the inverter output and verify it comes on and shines normally. DO NOT connect anything larger than a 25-watt light bulb until all wiring and voltages are confirmed to be correct.



Info: The inverter's AC output voltage will not be correct until a load greater than 5 watts (default setting) is connected to the inverter; or, the Search mode is turned off with a remote display (ME-RC, ME-ARC, ME-RTR). A 10-25 watt light bulb is used as it is a sufficient load to bring the inverter out of Search mode and up to full voltage.

5. Verify the AC output voltage of the inverter by connecting an AC voltmeter to the output terminals (see Figure 2-19).
6. Press and release the inverter's ON/OFF switch to turn the inverter off. The inverter's status indicator and the connected load should go off.
7. Apply AC power to the inverter's AC input. After the AC input power is qualified (approximately 15 seconds), the incoming AC power will transfer through the inverter to the inverter's AC output and power the light bulb. Verify the inverter's status indicator and the light bulb comes on.
8. Even though the light bulb is on, the inverter is currently disabled (off). Press and release the ON/OFF switch on the inverter to enable (turn on) the inverter.
9. Disconnect the incoming AC power to the inverter. Verify the light bulb remains on and is now powered by the inverter.

If the inverter passes all the steps, the inverter is ready for use. If the inverter fails any of the steps, refer to the Troubleshooting section.

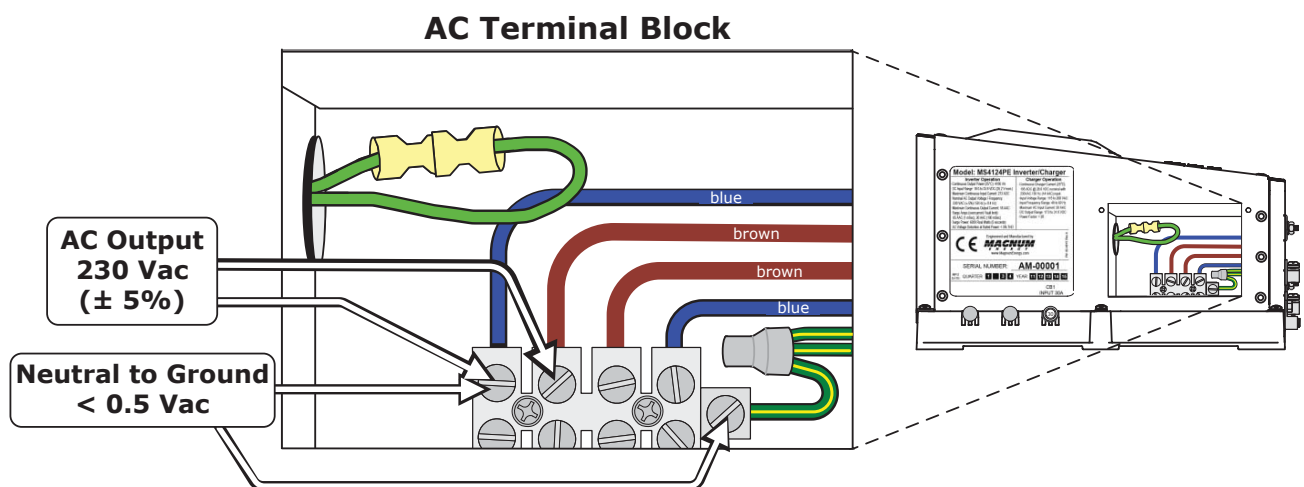

Figure 2-19, AC Voltage Checks

3.0 Operation

The MS-PE Series inverter has two normal operating routines; Inverter mode, which powers your loads using the batteries, and Standby mode, which transfers the incoming AC power (e.g., utility power or a generator) to power your loads and to recharge the batteries. This inverter also includes an extensive protection circuitry to shut down the inverter under certain fault conditions.

3.1 Inverter Mode

When the MS-PE Series is first powered up, it defaults to the OFF mode. The momentary ON/OFF power switch (see Figure 1-1, Item 1) must be lightly pressed to turn the inverter on. Subsequently, pressing this switch alternately turns the inverter off and on.

Inverter OFF – When the inverter is off, no power is used from the batteries to power the AC loads, and the status LED will be off. If AC power from an external source (utility grid or generator) is connected and qualified on the inverter’s AC input, this AC input power will pass through the inverter to power the AC loads. However, if this AC power is lost, the AC loads will no longer be powered because the inverter is off.

When the inverter is turned on, it operates either by “searching” or “inverting”, depending on the connected AC loads.

Searching – When the inverter is first turned on, the automatic Search feature is enabled. This feature is provided to conserve battery power when AC power is not required. In this mode, the inverter pulses the AC output looking for an AC load (e.g., electrical appliance). Whenever an AC load (greater than 5 watts) is turned on, the inverter recognizes the need for power and automatically starts inverting. When there is no load (or less than 5 watts) detected, the inverter automatically goes back into Search mode to minimize energy consumption from the battery bank. When the inverter is searching, the inverter’s green LED flashes (fast).



Info: The factory default value for the Search feature is 5 watts, it can be turned off or adjusted from 5 to 50 watts using a remote display (ME-RC, ME-ARC, or ME-RTR).

Inverting – When a load greater than 5 watts is connected to the inverter output, the MS-PE Series inverts the DC power from the battery and supplies 230 VAC power to your sub-panel. The inverter’s green LED flashes once every 2 seconds (medium flash) to indicate it is inverting. The amount of time the inverter can be inverting and providing power is directly related to the amount of AC loads that are connected, and the capacity of the battery bank. Refer to Figure 3-1 to see the flow of power from the DC input to the AC output while in the Inverter mode.

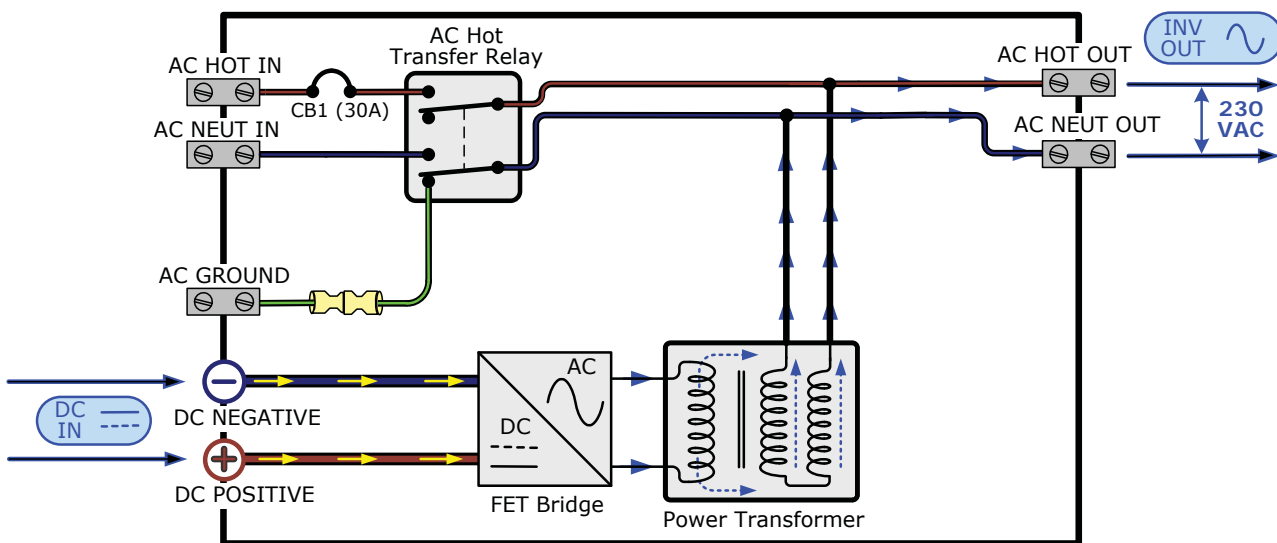

Figure 3-1, Power Flow - Inverter Mode

3.2 Standby Mode

The MS-PE Series features an automatic transfer relay and an internal battery charger when operating in Standby mode. Standby mode begins whenever AC power (utility grid or generator) is connected to the inverter's AC input. Once the AC voltage and frequency of the incoming AC power is within the AC input limits, an automatic AC transfer relay is activated. This transfer relay passes the incoming AC power through the inverter to power the AC loads on the inverter's output. This incoming power is also used to activate a powerful internal battery charger to keep the battery bank charged in case of a power failure. Refer to Figure 3-2 to see the flow of power from the AC input to the DC and AC output while in Standby mode.

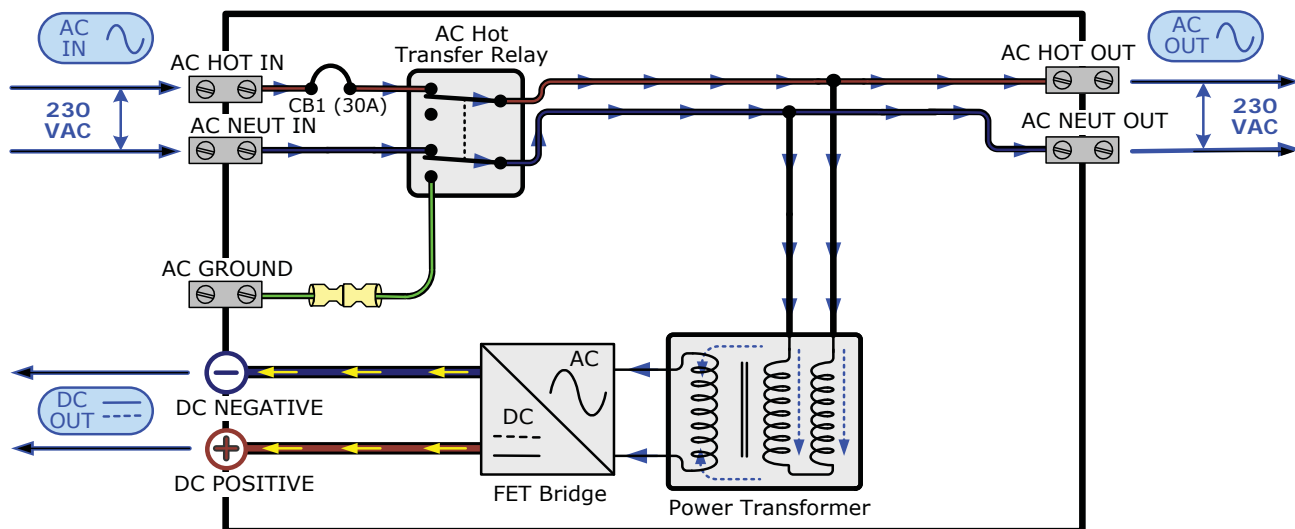

Figure 3-2, Power Flow - Standby Mode

3.3 Battery Charging

Magnum Energy's MS-PE Series is equipped with an active PFC (Power Factor Corrected) and PI (Proportional-Integral) multi-stage battery charger. The PFC feature controls the amount of power used to charge the batteries in order to obtain a power factor as close as possible to 1 (or unity). This causes the battery charger to look like a resistor to the line (forces the charge current wave shape to mirror the voltage wave shape). The PI feature allows the charger voltage and current to change independently. These two features maximize the real power available from either the utility or generator AC power sources, which translates into less power wasted and greater charging capabilities than most chargers available today.

When an AC source is connected to the AC input, the inverter begins monitoring for acceptable AC voltage. Once the inverter has accepted this AC voltage, the AC transfer relay closes and Charge mode begins. After Charge mode begins, the DC voltage is monitored to determine the charging stage. If the DC voltage is low (≤ 12.8 VDC/12-volt models or ≤ 25.6 VDC/24-volt models), the charger begins Bulk Charging. If the DC voltage is high (> 12.8 VDC/12-volt models or > 25.6 VDC/24-volt models), the charger will skip the Bulk and Absorb Charging stages and go directly to Float Charging. The multi-stage charger can use up to five different charging stages to help monitor and keep the batteries healthy. The five stages include an automatic 4-stage charging process: Bulk, Absorb, Float and Full Charge; and a manual Equalization (EQ) charge stage. The automatic 4-stage charge process provides complete recharging and monitoring of the batteries without damage due to overcharging. The EQ stage (requires a remote control display to enable) can be used to stir up stratified electrolyte and to reverse battery plate sulfation that may have occurred.

While charging, the unit may go into charger back-off protection, which automatically reduces the charge current to the batteries. This is caused by: 1) The internal temperature is too hot – the charger automatically reduces the charge rate to maintain temperature; or 2) The AC input voltage falls below 170 VAC – the charger stops charging to help stabilize the incoming AC voltage.

Operation

The Charge mode provides up to four separate charging stages: Bulk Charging, Absorb Charging, Float Charging, and Full Charge (see Figure 3-3).

- **Bulk Charging:** This is the initial stage of charging. While bulk charging, the charger supplies the battery with controlled constant current. The charger will remain in bulk charge until the absorption charge voltage (determined by the *Battery Type* selection*) is achieved. The inverter's green LED stays on (solid) to indicate bulk charging.
- **Absorb Charging:** This is the second charging stage and begins after the absorb voltage has been reached. Absorb charging provides the batteries with a constant voltage and reduces the DC charging current in order to maintain the absorb voltage setting. The inverter's green LED flashes once every second (fast flash) to indicate absorption charging for 2 hours (determined by the *Battery AmpHrs* selection*), then switches to float charging.
- **Float Charging:** The third charging stage occurs at the end of the absorb charging time. While float charging, the charge voltage is reduced to the float charge voltage (determined by the *Battery Type* selection*). In this stage, the batteries are kept fully charged and ready if needed by the inverter. The inverter's green LED flashes once every 8 seconds (slow flash) to indicate float charging. The Float Charging stage reduces battery gassing, minimizes watering requirements (for flooded batteries), and ensures the batteries are maintained at optimum capacity.
- **Full Charge (Battery Saver™ Mode):** The fourth stage occurs after four hours in the Float Charging stage. The Full Charge stage is designed to keep batteries fully charged over long periods and to prevent excessive loss of water in flooded batteries, or drying out of GEL/AGM batteries. In this stage, the charger is turned off and begins monitoring the battery voltage; if the battery voltage drops low (12.7 VDC or less on 12-volt models or 25.4 VDC or less on 24-volt models), the charger automatically initiates another four hours in float charge.



Info: If the battery voltage falls to the re-bulk voltage (24.2 VDC on 24-volt models or 48.4 VDC on 48-volt models) or lower, the unit will begin another bulk charge.

* These settings in the MS-PE Series are changeable and leave the factory with default values (see Table 3-2, Inverter/Charger Default Values). These default values are adequate for most installations; however, if you determine that some of the values need to be changed for your particular system, the ME-RC remote control may be purchased to adjust these settings.

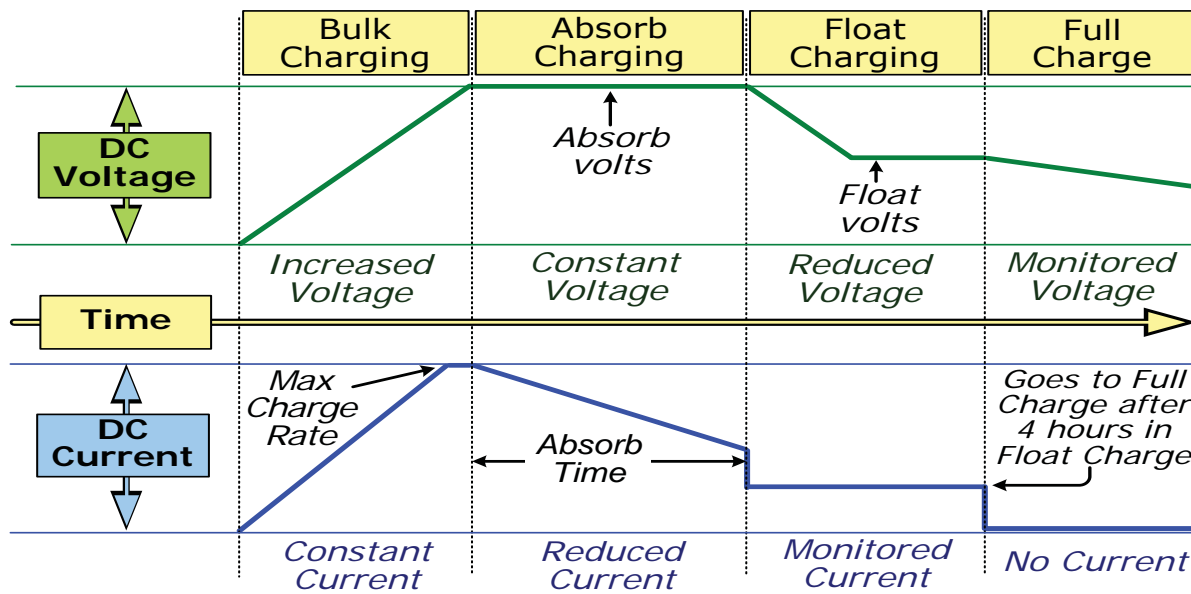

Figure 3-3, Automatic 4-Stage Charging Graph

3.4 Transfer Time

While in Standby mode, the AC input is continually monitored. Whenever AC power falls below the VAC dropout voltage (150 VAC, default setting), the inverter automatically transfers back to Inverter mode with minimum interruption to your appliances—as long as the inverter is turned on. The transfer from Standby mode to Inverter mode occurs in approximately 16 milliseconds. While the MS-PE Series is not designed as a computer UPS system, this transfer time is usually fast enough to hold them up. However, the VAC dropout setting has an effect on the ability of the loads to transfer without resetting. The lower this setting, the longer the effective transfer will be and therefore, the higher the probability for the output loads to reset. This occurs because the incoming AC voltage is allowed to fall to a level that is so low that when the transfer does occur, the voltage on the inverters output has already fallen to a level low enough to reset the loads.

The disadvantage of a higher VAC dropout setting is that smaller generators (or large generators with an unstable output) may nuisance transfer. This commonly happens when powering loads that are larger than the generator can handle—causing the generator’s output voltage to constantly fall below the inverter’s input VAC dropout threshold.



Info: When switching from Inverter mode to Standby mode, the inverter waits approximately 15 seconds to ensure the AC source is stable before transferring.

3.5 Battery Temperature Sensor Operation

The plug-in Battery Temperature Sensor (BTS) is used to determine the battery’s temperature. This information allows the multi-stage battery charger to automatically adjust the battery charge voltages for optimum charging performance and longer battery life.

When the BTS is installed, if the temperature around the BTS is below 25°C (77°F) the absorb and float charge voltage increases, and if the temperature around the BTS is higher than 25°C (77°F), the absorb and float charge voltage decreases. See Figure 3-4 to determine how much the charge voltage changes (increases or decreases) depending on the temperature reading of the BTS. For example, the nominal absorb charge voltage for a flooded battery at 25°C (77°F) on a 24-volt model is 29.2 VDC. If the battery temperature is 35°C (95°F), the absorb charge voltage would decrease to 28.6 VDC (29.2 VDC - 0.6 change).

If the temperature sensor is NOT installed, the charge voltages will not be compensated and the battery will maintain the charge it had at a temperature of 25°C (77°F). The life of the batteries may be reduced if they are subjected to large temperature changes when the BTS is not installed.



Info: When the BTS is connected, the battery charger uses a value of 5mV/°C/Cell from 0-50°C to change the charge voltage based on temperature.

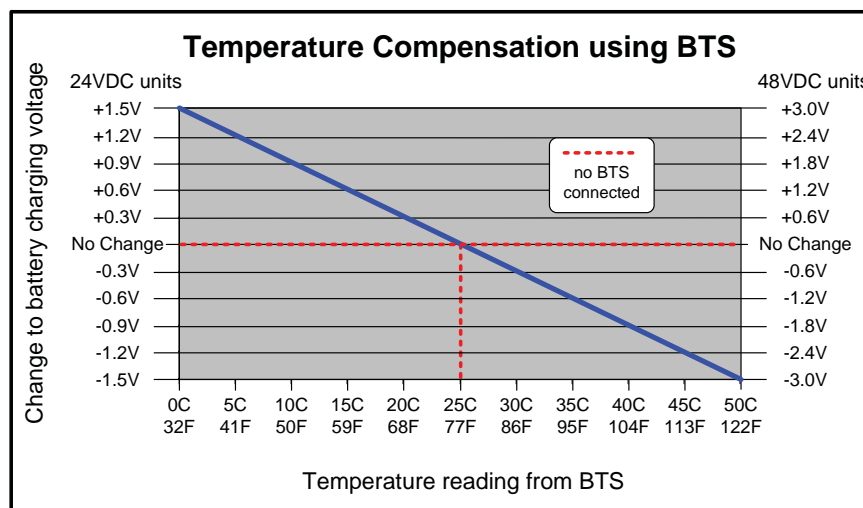

Figure 3-4, BTS Temperature to Charge Voltage Change

3.6 Protection Circuitry Operation

The inverter is protected against fault conditions and in normal usage it will be rare to see any. However, if a condition occurs that is outside the inverter's normal operating parameters, it will shut down and attempt to protect itself, the battery bank, and your AC loads. If there is a condition that causes the inverter to shut down, it may be one of the following conditions [also refer to the Troubleshooting section (Section 4.3) to help diagnose and clear the fault condition]:

- **Low Battery:** The inverter will shut off whenever the battery voltage falls to the Low Battery Cut Out (*LBCO*) level to protect the batteries from being over-discharged. After the inverter has reached the LBCO level and turned off, the inverter will automatically restart after one of the following conditions:
 - ◇ AC power is applied and the inverter begins operating as a battery charger, or
 - ◇ battery voltage rises to the Low Battery Cut In (*LBCI*) level

The inverter's status LED turns off when a low battery fault condition occurs. Refer to Table 3-1 to determine the LBCO and LBCI levels for your inverter model.

- **High Battery:** In the event the battery voltage approaches the High Battery Cut Out (*HBCO*) level, the inverter will automatically shut down to prevent the inverter from supplying unregulated AC output voltage. The inverter's status LED turns off when a high battery fault condition occurs. The inverter will automatically restart when the battery falls to the High Battery Cut In (*HBCI*) level. Refer to Table 3-1 to determine the HBCO and HBCI levels for your inverter model.



Info: High battery voltage may be caused by excessive or unregulated voltage from the solar panels or other external charging sources.

- **Overload:** During inverter and standby operation, the inverter monitors the DC and AC current levels. In the event of a short-circuit or an overload condition for more than a few seconds, the inverter will shut down. To start operating after this fault, the inverter must be restarted (turned back on) once the inverter's AC loads are reduced/removed.
- **Over-temperature:** If internal power components begin to exceed their safe operating temperature level, the inverter will shut down to protect itself from damage. The inverter's status LED turns off to indicate the over-temperature fault condition. The inverter automatically restarts after the unit cools down.
- **Internal Fault:** The inverter continually monitors several internal components and the processor communications. If a condition occurs that does not allow proper internal operation, the inverter will shut down to protect itself and the connected loads. The inverter will need to be reset to start operating again (refer to Section 4.4 for information on resetting the inverter).

Table 3-1, Inverter Battery Turn On/Off Levels

Inverter battery turn ON/OFF Levels	Inverter Model	
	MS4124PE	MS4348PE
HBCO	≥33.8 VDC	≥67.6 VDC
HBCI	33.2 VDC	66.4 VDC
LBCI	25.0 VDC	50.0 VDC
LBCO* (1 minute delay)	20.0 VDC (18.0 – 24.4 VDC)	40.0 VDC (36.0 – 48.8 VDC)
LBCO (immediate)	17.0 VDC	34.0 VDC

**adjustable with remote control*

3.7 Inverter Startup

Power ON/OFF Switch: The inverter can be turned on and off by lightly pressing and releasing the Power ON/OFF switch on the front of the inverter (see Figure 3-5). When the inverter is first connected to the batteries, or when its automatic protection circuit has turned the inverter off, the ON/OFF switch will need to be pressed to start the unit (or reset per Section 4.4). Once the inverter has been turned on, pressing the ON/OFF switch alternately turns the inverter on and off.



WARNING: The Power ON/OFF control switch does not turn on or off the charger feature. If AC power (utility or generator) is connected and qualified on the AC input, this AC power will also be available on the AC output and is not controlled by the Power ON/OFF switch.

Charging/Inverting Status LED Indicator: The status indicator is a green LED (Light Emitting Diode) that provides information on the operational mode of the inverter. Watch this indicator (see Figure 3-5) for at least 10 seconds to determine the inverter's operational condition from the information below:

- **Off** – Indicates the inverter is off; there is no AC power (inverter, utility, or generator) at the inverter's output terminals. If the LED stays off after pressing the ON/OFF switch, there is a "fault condition" such as low battery, high battery, overload, over-temperature, or an internal fault. Refer to the Troubleshooting section to help diagnose/clear the fault condition.
- **Blinks on 4 seconds, then is off 4 seconds** – Indicates Float Charging; the external AC input power is passing through the inverter and powering the AC loads connected to the inverter's output.
- **Blinks on once every second:**
 - When AC power is not connected to inverter input* – Indicates the inverter is on and using energy from the battery. The inverter is either: 1) Inverting – providing full power to the loads connected to the inverter; or, 2) Searching – conserving power and waiting for a load to be turned on that meets or exceeds the search watts parameter (5 watts is the default setting).
 - When AC power is connected to inverter input* – Indicates Absorb Charging; the inverter is in Standby mode (the external AC power that is connected to the inverter's input is passing thru the inverter and is powering the AC loads connected to the inverter's output).
- **On (solid)** – Indicates Bulk Charging; the external AC input power is passing thru the inverter and powering the AC loads connected to the inverter's output.

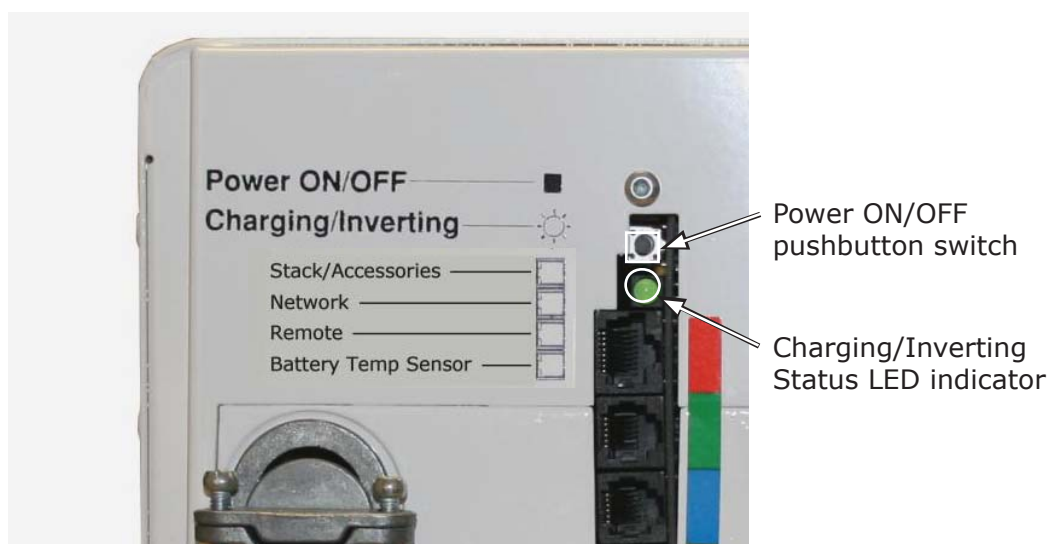

Figure 3-5, Power Switch and Status Indicator

Operation

3.8 Factory Default Values

Your MS-PE Series inverter/charger uses default values for the adjustable settings (see Table 3-2) that are adequate for most installations. If some of your operating parameters need to be changed from the default values, an optional remote display can be used to make those changes. To help you determine if you need a remote display, information on the changeable inverter/charger settings is provided below. Once programmed, the settings are saved in the remote's non-volatile memory and are preserved until changed—even if DC power to the inverter is lost (as long as the remote display is connected). For information on the full range of settings for each function in your remote display, refer to its owner's manual at www.magnumenergy.com.

- **Shore Max/Input Amps:** This setting ensures the inverter AC loads receive the maximum current available from the utility or generator power. When the total current used to power the AC loads and to charge the batteries begins to approach the *Shore Max* setting, the current that was used for charging the batteries will automatically be reduced.
- **Search Watts:** This setting allows you to turn off the power-saving Search mode circuitry, or to adjust the power level at which the inverter will “wake up” and start inverting.
- **LowBattCutOut:** This setting determines when the inverter will turn off based on low battery voltage. The inverter turns off automatically after the battery voltage has been below this setting for more than one minute. This protects the batteries from over-discharge and the AC loads from unregulated power (brown-outs).
- **Batt AmpHrs/Absorption Time:** This setting allows the user to input the battery bank size in amp hours or to set the absorption time—which tells the charger how long to charge the batteries in the Absorb Charge stage.
- **Battery Type:** Sets the type of batteries being used in the system. This information tells the charger what voltage level to use to charge the batteries.
- **Charge Rate:** This setting can be used to turn off the charger, limit the amount of current that the charger can use (leaving more current available to power loads), or to ensure small battery banks are not overheated because of a charge rate that is too high.
- **VAC Dropout:** Sets the minimum AC voltage that must be present on the AC input before the unit transfers from Standby mode to Inverter mode. This protects the AC loads from utility outages and brown-outs.

Using a remote display also provides the following features:

- allows you to enable an equalize charge for certain battery types
- displays inverter/charger's operating status
- provides fault information for troubleshooting



Info: Specific adjustments that are set using a remote control will be lost if the remote is unplugged and battery power is shut off to the inverter/charger.

Table 3-2, Inverter/Charger Default Values

Adjustable Settings	Default Values
Shore Max/Input Amps	30 Amps
Search Watts	5 Watts
LowBattCutOut	24v = 20 VDC (one min. delay) 17 VDC (no delay) 48v = 40 VDC (one min. delay) 34 VDC (no delay)
Batt AmpHrs/Absorption Time	600 AmpHrs (Absorb Time = 120 minutes)
Battery Type	Flooded – Liquid Lead Acid: 24v = Absorb 29.2 VDC, Float 26.8 VDC 48v = Absorb 58.4 VDC, Float 53.6 VDC
Charge Rate	100%
VAC Dropout	150 VAC

3.9 Inverter Fan Operation

The inverter contains two internal cooling fans that are automatically controlled. The speed of these fans is determined either by the internal temperature of the inverter or by the load on the inverter. The inverter's fans will come on under the conditions listed below:

- Fans run full speed if the internal transistors (FETs) or the power transformer reaches 80°C (176°F), or the inverter is running at 100% of its rated load.
- Fans run medium speed if the internal transistors (FETs) or the power transformer reaches 60°C (140°F), or the inverter is running at 50% of its rated load.
- Fans run low speed when the inverter is running at 25% of its rated load.

The fans shut down when none of the above conditions are met, or if the battery voltage is below 19.0V (24-volt systems) or 38.0V (48-volt systems).

Whenever the inverter is first connected to the battery, the fans start for about one second. The inverter's fans will not start based on temperature sensed by the optional BTS.

3.10 Using a Remote with the MS-PE Series Inverter

The MS-PE Series inverter is a Level 4 inverter, which means it can communicate with any Magnum remote (ME-RC, ME-ARC or ME-RTR) to allow the advanced features in the remote to be set up or enabled.

Table 3-3, Inverter Compatibility Level

INV/CHG Models	Level 1 (L1)	Level 2 (L2)	Level 3 (L3)	Level 4 (L4)
MS4124PE	NA	NA	NA	≥ Rev 5.5
MS4348PE	NA	NA	NA	≥ Rev 5.5

3.10.1 Remote Compatibility

Older remote revisions will work with the MS-PE Series. However, to view the correct 230 VAC readings and settings, the following remote revisions are required.

Table 3-4, Remote Compatibility Level

Remote Models	Revision Required
ME-RC	≥ Revision 2.7
ME-ARC	≥ Revision 2.4
ME-RTR	≥ Revision 3.0

Operation

3.11 Parallel Operation

This section provides information about operating the MS-PE Series inverters in parallel.

IMPORTANT: You must have a ME-RTR router to parallel stack multiple inverters. Refer to the ME-RTR Owner's Manual for info on setting up and turning on a parallel system.



WARNING: The information in this section is meant to supplement the information in previous sections. To prevent personal injury or equipment damage, you must carefully read and follow all instructions and warnings in this owner's manual.

3.11.1 Overview

A single MS-PE inverter produces 230VAC at its rated power (i.e., MS4124PE provides 4100 watts of inverter power). Parallel stacking synchronizes multiple inverters to work together as a single inverter/charger system that increases the inverters' continuous and surge capacity, the charging capability to the battery bank, and the AC pass-through capacity.

The ME-RTR router allows MS-PE Series inverters to operate in phase by having one of the inverters operate as the "master" and the others as "slaves" (slaves are controlled by the master). When first turned on, all the stacked inverters are powered and then begin to monitor the power required by the AC load. If the power requirement by the AC load decreases, the slave inverters power down into Power Standby mode until needed. Power Standby mode allows the inverters to shut down to reduce power consumption and to quickly begin inverting when the loads demand more power. Because the paralleled inverters operate as a single unit, the total battery charging capability and AC pass-through capacity are also increased. This helps with fuel consumption efficiency and allows available current to transfer to loads when using large generators. When the generator (or utility power) is connected to the parallel system, the master inverter first synchronizes, then connects. Since the slave inverter(s) follow the master inverter, they are prevented from connecting until the master inverter has synchronized and connected. After the full system has connected, battery charging begins. This allows a smooth transition from Inverter mode to Charger mode since the slave inverters are already synchronized when they transfer the loads and start battery charging.

3.11.1.1 Conditions for Parallel System

When connecting units in parallel, the following requirements must be met:



Info: Magnum's MP-E & MMP-E Series enclosures meet the requirements for parallel stacking MS-PE inverters for a code compliant installation.

- Only MS-PE Series inverters are capable of being stacked in parallel. All inverters stacked together must be the same model (i.e., MS4124PE with another MS4124PE).
- A maximum of four MS-PE inverters can be connected in parallel (must be same model).
- The ME-RTR router must be connected to communicate and synchronize with the other MS-PE inverters for parallel operation, and must be within 1.8 meters (6') of the stacked inverters.
- The Router Sync cable that is provided with the ME-RTR router must be used to connect directly from the ME-RTR to each inverter. This cable is the only one that meets a parallel system's size, data, and insulation requirements.
- The inverters must be connected to the same battery bank.
- The DC connection cables from the battery to the inverter must be of equal length and size.
- The inverter's negative terminals must be connected together either at the inverters or at a location close to the inverters (within 45.7 cm/18 inches).
- The AC input/output cables to/from each inverter must be of equal length and size (length to AC input may be different from length to AC output).
- Place the MS-PE inverters close to each other to allow the 6 ft router sync cable to connect to each inverter—they should be no more than 15.2 cm (6") from each other, but allow at least 7.6 cm (3") for ventilation purposes under, above, and in front of each inverter.
- The AC input to every inverter must be from the same 230 VAC AC source.
- Each inverter must have appropriate AC and DC overcurrent protection.
- All negative connections (i.e., inverter, battery) must be permanently connected to each other. No fuse or disconnect can be placed in the negative circuit.

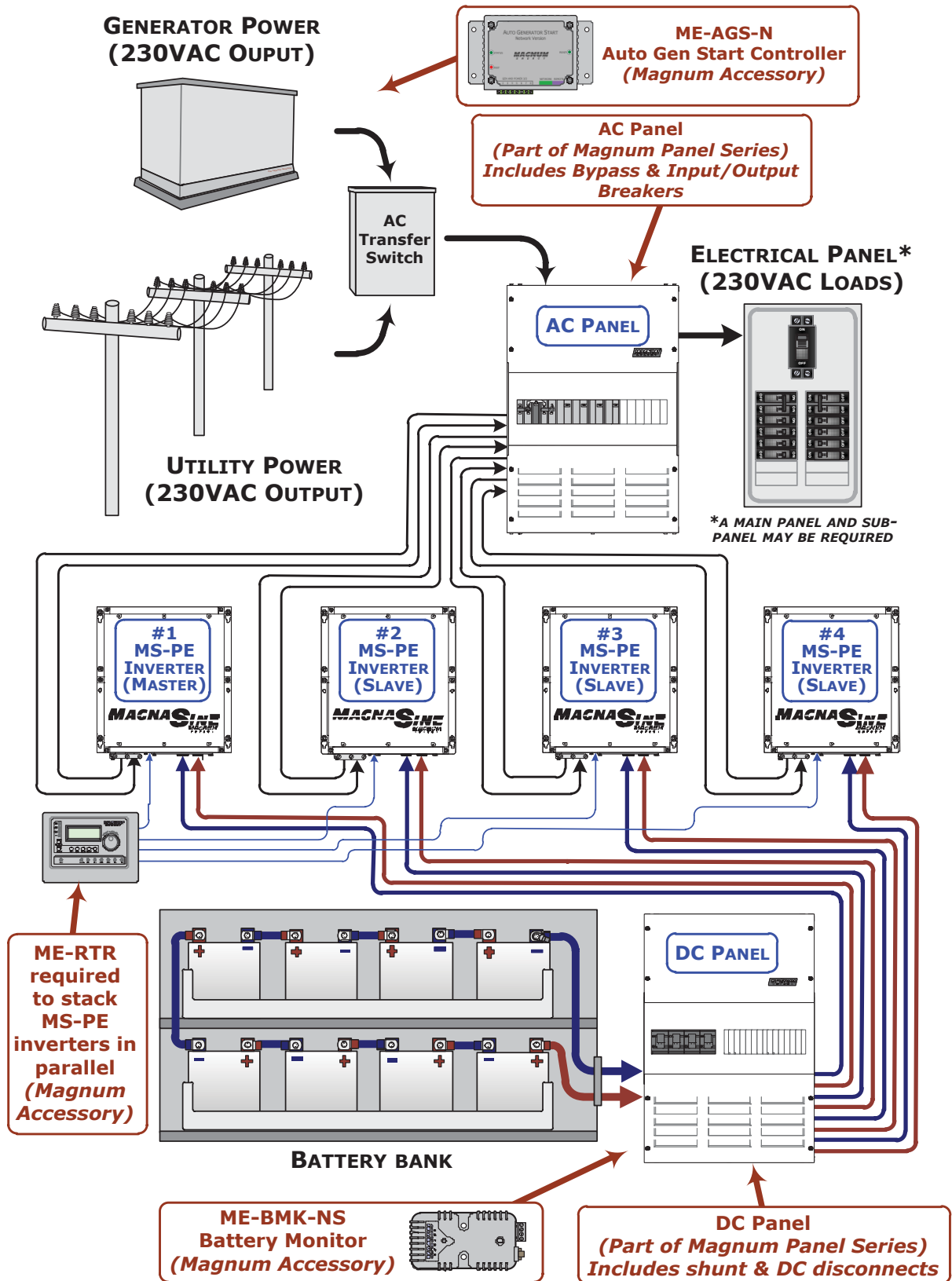

Figure 3-6, Simplified Installation Diagram – Multiple Inverters (in parallel)

Operation

3.11.2 Parallel System Connections and Components

The basic installation procedure of the parallel system is similar to that of a single inverter system. However, the AC and DC connections and components required in the parallel system must be considered.

3.11.2.1 AC and DC Connections Simplified Using Magnum Panels

The AC and DC connections in the parallel system depend upon other components (noted in the two sections below in **bold**), but are simplified when using the Magnum Panel (MP-E & MMP-E) Series of enclosures. As shown in Figure 3-6, the AC panel and DC panel—which are part of the MP-E & MMP-E Series enclosures—provide these separate components; and the specific AC or DC wiring to these components are completed for you. Figures 3-7 and 3-8 are simplified diagrams of the AC and DC panels showing the connections and components.

3.11.2.2 AC Connections Required in Parallel System

The AC input supply to the parallel system must be a 230 VAC system that provides one line conductor, a neutral, and a ground. Each MS-PE inverter requires a single-pole circuit breaker rated for a maximum 30A. Typically the AC supply originates in a main distribution panel, providing the separate **AC breakers** required for the AC input of each MS-PE inverter. This main panel also has to provide the **AC busbars** to allow connection of the neutral and ground conductors to each inverter input.

The AC output side of the parallel system requires an electrical panel—referred to as the inverter panel—that combines all the inverter outputs and is equipped with a large circuit breaker rated for the total output current of the parallel system. This inverter panel must provide the **AC busbars** for the neutral and ground conductors from each inverter output.

If the inverter system requires isolation from the AC source for servicing without losing power to the AC loads, an **AC bypass** should be installed between the AC input and output connections.

3.11.2.3 DC Connections Required in Parallel System

When inverters are stacked they must operate from a common battery bank. In other words, the DC negative of one inverter must be common with the second inverter and likewise for the DC positive. Each inverter must be wired to the single battery bank separately and have a **DC breaker** in the positive side, matched to the cable size.

All DC negatives are required to be combined on a **DC busbar** and if the system requires battery bank monitoring, a full system **DC shunt** will need to be installed in the DC negative side.

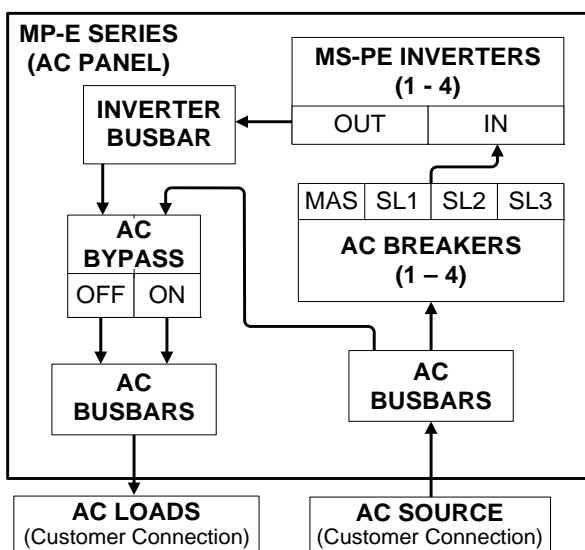

Figure 3-7, Simplified Magnum Panel (AC Panel)

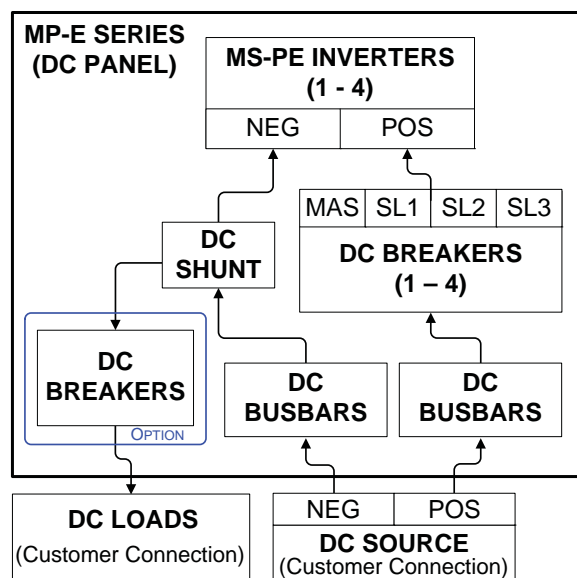

Figure 3-8, Simplified Magnum Panel (DC Panel)

4.0 Maintenance and Troubleshooting

The following information is provided to help you keep your MS-PE Series inverter/charger in optimum operational condition.

4.1 Recommended Inverter and Battery Care

The MS-PE Series inverter/ charger is designed to provide you with years of trouble-free service. Even though there are no user-serviceable parts, it is recommended that every 6 months you perform the following maintenance steps to ensure optimum performance and extend the life of your batteries.



WARNING: Prior to performing the following checks, switch OFF both the AC and DC circuits.

- Visually inspect the batteries for cracks, leaks, or swelling—replace if necessary.
- Use baking soda to clean and remove any electrolyte spills or buildups.
- Check and tighten all battery hold down clamps (if applicable).
- Clean and tighten all battery terminals and connecting cables [10 to 12 ft lbf (13.6 to 16.3 N-m)].
- Check and fill battery water levels (Liquid Lead Acid batteries only).
- Check individual battery voltages (load test those that have a voltage difference of more than 0.3 VDC from each other)—replace if necessary.
- Check all cable runs for signs of chafing—replace if necessary.
- Check the inverter's cooling vents—clean as necessary.
- Check and tighten the inverter's internal AC terminal block connections [16 in lbf (1.8 N-m)].

4.2 Storage for Mobile Installations

When placing the boat or caravan into storage, it is recommended that you perform the following to ensure the system is properly shut down (or properly configured for storage). This is especially important for maintaining the batteries.

- Perform the recommended maintenance steps listed in Section 4.1.
- Fully charge the batteries.
- Connect AC power (if available) and verify the breaker to the inverter's input is switched ON (to allow battery charging).
- Verify the inverter is switched OFF.
- Switch OFF all unnecessary AC and DC loads.
- Disable the AGS (if installed) when the boat or caravan is in a confined storage area.



WARNING: If an AGS were to start and run the generator for an extended period of time in a confined area, a potentially fatal level of carbon monoxide (CO) could accumulate.

Maintenance and Troubleshooting

4.3 Troubleshooting

The MS-PE Series inverter/charger is a fairly simple device to troubleshoot. There are only two active circuits (AC and DC), as well as a charging circuit. The following chart is designed to help you quickly pinpoint the most common inverter failures.

Table 4-1, Basic Troubleshooting (remote not available)

Symptom	Possible Cause	Recommended Solution
No output power. Inverter LED is OFF.	Inverter is switched OFF.	Switch the inverter ON.
	Battery voltage is too low. The battery voltage level has dropped below the Low Battery Cut Out (LBCO) set-point for more than one minute.	Check fuses/circuit breakers and cable connections. Check battery voltage at the inverter's terminals. Your batteries may need to be charged, this fault condition will automatically clear when the battery voltage exceeds the LBCI voltage.
	The battery voltage is too high. The inverter automatically resets and resumes operation when the battery voltage drops to the HBCI voltage or lower.	This condition usually occurs only when an additional charging source (alternator, solar panels, or other external charging sources) is used to charge the battery bank. Reduce or turn off any other charger to the inverter batteries to allow the voltage level to drop.
	Over-temperature condition: The internal temperature of the inverter has risen above acceptable limits; caused by loads too great for the inverter to operate continuously, or by lack of ventilation to the inverter. When the unit has cooled, it will automatically reset and resume operation.	Reduce the number of electrical loads that you are operating. This will avoid a repeat over-temp shutdown if the cause was too many loads for the ambient conditions.
		Check ventilation around the inverter, ensure cool air is available to pass through the inverter (refer to the ventilation requirements in Section 2.1.3).
	AC overload condition: The inverter has turned off because the connected loads are larger than the inverter's output capacity, or the output wires are shorted.	Reduce the AC loads connected to the inverter, or remove all AC output wiring and restart the inverter.
Internal fault: This fault occurs when an internal fault is detected.	To clear this fault, an inverter reset is required. See Section 4.4 to perform an inverter reset.	
No output power. Green LED is flashing once/second.	Unit is in Search mode, which means the load is too small for Search mode circuit detection.	Turn on a load greater than 5 watts to bring the inverter to full output power.
No output power. Green LED is flashing quickly—fluttering.	Unit is in continuous reset.	Check that the inverter's Power ON/OFF switch is not stuck in the ON position (ensure you can feel a click when pushing). If not, inverter requires repair/service.
Low output or surge power. Green LED is flashing.	Loose or corroded battery cables.	Clean and tighten all cables.
	Low batteries.	Recharge or replace batteries.
	Loose AC output connections.	Tighten AC output connections.
	Battery cables are the wrong length or gauge.	Verify recommended cable lengths and gauges from the manual. Replace cables as necessary.
Low charging rate when connected to AC power.	Charge rate backing off due to high temperature inside the inverter.	Provide better inverter ventilation/cooling, or additional battery chargers needed if battery bank is very large.
	Low AC voltage (<170 VAC).	Check AC input wiring.
Low charging rate when using a generator.	Generator output is too low to power both the load and charger.	Reduce the load, increase the generator's RPMs.
Charger doesn't charge.	Loose or corroded battery cables.	Clean and tighten battery cables.
	Defective batteries.	Replace batteries.
	Wrong AC input voltage.	Verify proper AC input voltage and frequency.
While charging, the DC charge voltage is higher or lower than expected.	If the Battery Temperature Sensor (BTS) is installed, the DC voltage will increase or decrease depending on the temperature around the BTS.	This is normal; see Section 3.5 (Battery Temperature Sensor Operation) for more information.

4.4 Resetting the Inverter

Under some fault conditions (e.g., an internal fault), the inverter will need to be reset.

4.4.1 Performing an Inverter Reset

To perform an inverter reset (also known as a “soft reset”):

1. First, ensure all AC power (i.e., shorepower or generator) is removed from the inverter’s input
2. Press and hold the Power ON/OFF pushbutton (see Figure 4-1) for approximately ten (10) seconds until the Charging/Inverting Status LED comes on and flashes rapidly.
3. Once the rapid flashing has begun, release the Power ON/OFF pushbutton. The Status LED will go off after the pushbutton is released.
4. After the inverter reset is completed, press the ON/OFF pushbutton to turn the inverter ON.

Some older inverter models do not allow an inverter reset. If the inverter reset fails, you will need to perform a power reset using the procedure below in Section 4.4.2. In either case, if an internal fault does not clear, the inverter will require repair at a Magnum Authorized Service Center (ASC).



Info: The Power ON/OFF pushbutton is a small *momentary* type switch which operates by lightly pressing and releasing. Be careful not to apply too much force when pushing or the switch might break.



1. Press and hold the Power ON/OFF pushbutton.
2. Watch the Charging/Inverting Status LED, after approximately 15 seconds it should come on and flash rapidly to indicate the inverter has reset. The Status LED will go off after the pushbutton is released.

Figure 4-1, Performing an Inverter Reset

4.4.2 Performing a Power Reset

To perform a power reset (also known as a “hard reset”):

1. Remove all AC power (utility or generator power) to the inverter.
2. Open all the inverter DC disconnects (or disconnect the positive battery cable to the inverter).
3. Ensure the inverter and the remote are disconnected from all AC and DC power (the remote display will be blank).
4. After the inverter has been disconnected from all power for 30 seconds, reconnect the inverter DC disconnects (or reconnect the positive battery cable) and resume operation.



Info: If DC disconnects are not used, there may be a momentary spark when the positive battery cable is connected to the inverter’s terminal. This is normal and indicates that the inverter’s internal capacitors are being charged.

Appendix A – Specifications and Optional Equipment

Appendix A – Specifications and Optional Equipment

A-1 Inverter/Charger Specifications

Models	MS4124PE	MS4348PE
Inverter Specifications		
Input battery voltage range	18-34 VDC	36-64 VDC
Absolute maximum DC input	50 VDC	68 VDC
Nominal AC output voltage	230 VAC \pm 5% (\leq continuous power)	
Output frequency and accuracy	50 Hz \pm 0.4 Hz	
Total Harmonic Distortion (THD)	<5%	
Continuous power output (at 25° C)	4100 VA	4300 VA
Continuous AC output current (amps AC)	17.8	18.7
1 msec surge current (amps AC)	65	75
100 msec surge current (amps AC)	30	37
5 sec surge power (real watts)	6300	7500
30 sec surge power (real watts)	5300	7100
5 min surge power (real watts)	4750	6600
30 min surge power (real watts)	4600	5000
Maximum continuous input current	273 ADC	143 ADC
Inverter efficiency (peak)	90%	91%
HBCO/HBCI (High Battery Cut Out/In)	33.8 VDC/33.2 VDC	67.6 VDC/66.4 VDC
LBCO/LBCI (Low Battery Cut Out/In)	18.0 VDC (adj)/25.0 VDC	36.0 VDC (adj)/50.0 VDC
Parallel stacking	Yes, up to 4 inverters when using the ME-RTR	
AC relay transfer time (minimum)	~ 20 mSec	
Power consumption - searching	9 watts	10 watts
Power consumption - inverting (no load)	30 watts	28 watts
Output waveform	Pure Sine Wave	
Charger Specifications		
Continuous charger output at 25°C	105 ADC	55 ADC
Input current at rated output (AC amps)	14	16
Charger efficiency	88%	91%
AC input frequency range	40-60 Hz	
AC input voltage range	110-268 VAC	
Power factor	>0.95	
General Features and Capabilities		
Transfer relay capability	30 amps AC	
Five-stage charging capability	Bulk, Absorb, Float, Equalize (requires remote), and Battery Saver™	
Battery temperature compensation	Yes, 4.6 m (15 ft) Battery Temp Sensor standard	
Internal cooling	0 to 120 cfm variable speed drive using dual 92 mm brushless DC fans	
Overcurrent protection	Yes, with two overlapping circuits	
Over-temperature protection	Yes on transformer, MOSFETS, and battery	
Corrosion protection	PCB's conformal coated, powder coated chassis/top, stainless steel fasteners	
Safety/certifications	CE and C-Tick compliance when installed with MS-CEFB	
Warranty	2 years, can be extended to 5 years (see Warranty)	
Operating temperature	-20°C to +60°C (-4°F to 140°F)	
Non-operating temperature	-40°C to +70°C (-40°F to 158°F)	
Operating humidity	0 to 95% RH non-condensing	
Physical Specifications		
Unit dimensions (l x w x h)	34.9 cm x 32.1 cm x 20.3 cm (13.75" x 12.65" x 8.0")	
Shipping dimensions (l x w x h)	38.1 cm x 44.5 cm x 31.8 cm (18.5" x 17.5" x 12.5")	
Mounting	Shelf (top or bottom up) or wall	
Unit weight	24.5 kg (54 lb)	
Shipping weight	27.7 kg (61 lb)	
Max operating altitude	4570 m (15,000')	
<i>Specifications @ 25°C - Subject to change without notice.</i>		

A-2 Optional Equipment and Accessories

The following Magnum Energy components are available for use with the MS-PE Series inverter/charger. Some of these items are required depending upon the intended use of the inverter.

CE Filter Box

The CE Filter Box (PN: MS-CEFB) is an EMI filter designed to control conducted emissions on the AC and DC side of Magnum Energy MS-E and MS-PE Series inverters. It is used to ensure the stringent international standards for electromagnetic compatibility (EMC) are met. The MS-E and MS-PE Series inverters—when connected to the MS-CEFB—conform to CE Mark requirements for European countries and C-Tick Mark requirements for Australia and New Zealand.

MMP-E Series Enclosures

The MMP175-E and MMP250-E enclosures are specifically designed for European and single inverter applications. The MMP-E Series enclosures combine all of the major components required for a renewable energy system into a single, easy to install pre-wired enclosure. These include: inverter/battery disconnect, AC overcurrent protection, grounding connections, and a full system inverter bypass switch as a convenient way to isolate the inverter for battery maintenance.

MP-E Series Enclosures

The MP-SL-175PE, MP-SL-250PE, MP-DH-175PE, and MP-DH-250PE enclosures have been specifically designed to combine MS-PE inverters when configured for parallel operation. The MP-E Series enclosures feature convenient front-mounted AC and DC connections and easy panel operation when using the optional ME-RTR router. Choose the MP-E model based on your power capacity needs. Each model is expandable, start with the base model and just one inverter, and in the future add another inverter—up to four inverters total depending on your model—with ease, using Magnum’s MPXS-PE expansion boxes.

Router Control

The ME-RTR router control display provides operating information and setup/troubleshooting capabilities for multiple Magnum inverters. Allows up to four MS-PE inverters to be connected in a parallel configuration for increased inverter power.

Advanced Remote Control

The ME-ARC remote control uses an LCD screen and at-a-glance LEDs to provide operating information and to allow advanced features to be configured (requires Magnum inverters with advanced configurable features). This LCD remote control also provides advanced monitoring/troubleshooting and includes a FAVS button to access your favorite features quickly.

Standard Remote Control

The ME-RC remote control uses an LCD screen and at-a-glance LEDs display complete inverter/charger status. Soft keys provide simple access to menus, and a rotary encoder knob allows you to scroll through and select a wide range of settings such as: Inverter ON/OFF, Charger ON/OFF, shorepower breaker setting, AGS control, meter displays, and Setup and Tech menus.

Auto Generator Start Controller

The ME-AGS-N Automatic Generator Start controller (Network version) is designed to automatically start your generator based on low battery condition or high temperature. The AGS controller includes an input voltage jumper (for 12, 24, and 48-volt battery banks) and a 4-position DIP (Dual In-line Package) switch which provides the ability to change the relay timing configurations to allow compatibility with a wider range of generators. The ME-AGS’s adjustable settings can be used to start the generator based on: battery voltage, time of day, battery ‘State of Charge,’ or high temperature. Includes Quiet Time with an easy to set clock. AGS settings do not interfere with the manual start/stop operation of the generator.

Battery Monitor Kit

The ME-BMK Battery Monitor Kit is a single battery bank amp-hour meter that monitors the condition of the battery, and provides information to let you know how much energy you have available and to let you plan your electrical usage to ensure the battery is not being over-discharged. The

Appendix A – Specifications and Optional Equipment

The ME-BMK-NS version does not include a DC shunt. You must order the ME-BMK to receive a 500A/50mv DC shunt.

Note: The DC shunt is included with MMP-E and MP-E Series enclosures. Order the ME-BMK-NS version when installed with the MMP-E or MP-E enclosures.

MagWeb-W

The MagWeb - Wireless (ME-MW-W) is a powerful and cost effective tool for remotely monitoring Magnum Energy's inverters and accessories. Installed on the Magnum network, the MagWeb provides live internet monitoring of the inverter, battery monitor, and automatic generator start module. Using your always on Internet connection, the MagWeb makes live and historical conditions available to you.

ME-CB and MPX-CB Conduit Boxes

The ME-CB and MPX-CB conduit boxes are provided for installations where the electrical code requires AC and/or DC wiring to your Magnum inverter to be enclosed and protected by conduit.

Smart Battery Combiner

The Smart Battery Combiner (ME-SBC) is designed to monitor and charge a second battery using a portion of the current that is charging the main battery. The ME-SBC eliminates a significant voltage drop, and provides automatic turn-on and turn-off based on adjustable voltage set-points. This allows different batteries to be charged from a single charging source, and prevents overcharging/undercharging.

Fuse Block/Fuses

Magnum fuse/fuse blocks are used to protect the battery bank, inverter, and cables from damage caused by DC short circuits and overloads. They include a slow-blow fuse with mounting block and protective cover. The 125 and 200-amp models use an ANL type fuse and the 300 and 400-amp models use a Class-T fuse.

A-3 Wiring Color Codes for Europe and the U.S./Canada

The following tables contrast AC and DC wiring color codes for Europe and the United States/Canada. In the U.S., the National Electrical Code (NEC) is the mandating authority; in Canada, it's the Canadian Electrical Code (CEC). Most of Europe abides by the International Electrotechnical Commission's (IEC) wiring color codes. The tables also list the labels that Magnum Energy applies to identify AC/DC wiring usage in its inverters.

Table A-1, AC Wiring Color Codes

Use	Magnum Label	Europe	U.S./Canada
Protective earth	AC GROUND	Green w/ yellow stripe	Bare, green
Neutral (out/in)	NEUT OUT/NEUT IN	Blue	White (marked white)
Line, single phase (out/in)	HOT OUT/HOT IN	Brown	Black

Table A-2, DC Wiring Color Codes

Use	Magnum Label	Europe	U.S./Canada
Positive circuit	Positive (+) terminal (w/ red cover)	Brown	Red
Negative circuit	Negative (-) terminal (w/ black cover)	Blue	White

Note: Table A-2 is based on a 2-wire negative earthed (grounded) DC power system.

Appendix B - Battery Information

B-1 Battery Location

Periodic maintenance (e.g., checking connections, cleaning, watering) on batteries is required. Locate the batteries in an accessible location to perform this maintenance.

Batteries must be mounted in a clean, dry, ventilated environment where they are protected from high and low temperatures. The battery bank should be located as close to the inverter as possible without limiting access to the inverter's disconnects. Longer battery cable runs tend to lose efficiency and reduce the overall performance of an inverter.

To ensure optimum performance, a ventilated battery enclosure is recommended. Two feet (61 cm) of clearance above the batteries is recommended for access to the battery terminals and the removable caps (lead acid battery types).



WARNING: Be very careful when working around batteries, they can produce extremely high currents if they are short-circuited. Read the important safety instructions at the beginning of this manual and the precautions from the battery manufacturer before installing the inverter and batteries.



CAUTION: Do not mount the batteries beneath the inverter (or in the same compartment). Batteries emit corrosive fumes which could damage the inverter's electronics. Never locate dedicated batteries near a vehicle/home fuel tank containing gasoline or propane.

B-2 Battery Types

Batteries are available in different sizes, amp-hour ratings, voltage, and chemistries. They are also available for starting applications (such as an automobile battery) and deep discharge applications. Only the deep cycle types are recommended for inverter applications; using a starting battery in an inverter (deep cycle) application will greatly shorten their useful life. Choose the batteries best suited for the inverter installation and cost. Use only the same battery type for all batteries in the bank. For best performance, all batteries should be from the same lot and date. This information is usually printed on a label located on the battery.

B-3 Battery Temperature

Battery performance of lead-acid type batteries is greatly affected by extreme temperatures. When a lead-acid type battery is cold, its effective amp-hour capacity is reduced. When determining the battery requirements needed for the inverter system, realize that the battery capacity will be reduced if they will be installed in a climate where extremely cold temperatures are expected. In this type of environment, the batteries should be located in a heated area. At the minimum, the batteries should be installed in an insulated enclosure; which will keep the batteries warmer as they are being charged.

The battery bank should also be protected from high temperatures, which will shorten battery life. In high heat situations the battery room/enclosure should be ventilated to bring in cooler air and exhaust the hotter air. The performance of the battery bank/inverter system will substantially increase by monitoring and preventing extreme temperatures around the batteries.

B-4 Battery Bank Sizing

The size of the battery bank determines how long the inverter will power the AC loads without recharging. The larger the battery bank, the longer the run time. Size your battery bank to the systems AC load requirements and length of time required to run from the batteries. In general, the battery bank should not be discharged more than 50%. Additional DC charging devices such as solar, wind, hydro, etc., can provide longer run times by recharging the batteries in the absence of AC utility or generator power.



Info: For the MS-PE Series inverter/charger to perform optimally, a minimum battery bank of 200 Ahr is recommended for moderate loads (<1000W) and greater than 400 Ahr for heavy loads (≥1000W).

Appendix B – Battery Information

B-5 Battery Bank Sizing Worksheet

Complete the steps below to determine the battery bank size required to power your AC loads:

1. Determine the daily power needed for each load.

- List all AC loads required to run; and
- List the Watt-Hours (Wh) for each load (see Table C-1 for common loads/wattage); and
- Multiply by how many hours per day (or a fraction of an hour) each load will be used; and
- Multiply by how many days per week you will use the listed loads; and then
- Divide by seven = **Average Daily Watt-Hours Per Load.**

Average Daily Watt-Hours Per Load				
AC load	Watt-Hours	(x) hours per day	(x) days per week	(÷7) = daily Wh/load

2. Determine the total power needed each day for all the loads.

- Add the *Average Daily Watt-Hours Per Load* together = **Total Daily Watt-Hours.**

Total Daily Watt-Hours

3. Determine the battery Amp-Hour capacity needed to run all the loads before recharging.

- Divide the *Total Daily Watt-Hours* by the nominal battery voltage of the inverter (i.e., 12, 24 volts); and
- Multiply this by how many days the loads will need to run without having power to recharge the batteries (typically 3 to 5 days of storage) = **Storage Amp-Hours.**

(inverter battery voltage)

÷ _____ =

(days of storage)

x _____ =

4. Determine how deeply you want to discharge your batteries.

- Divide the *Storage Amp-Hours* by 0.2 or 0.5 to get the **Total Amp-Hours:**
 - 0.2 = Discharges the batteries by 20% (80% remaining), this is considered the optimal level for long battery life; or
 - 0.5 = Discharges the batteries by 50% (50% remaining), this is considered a realistic trade-off between battery cost and battery life.

Total Amp-Hours

Additional compensation:

Low battery temperature: If the batteries are installed in a location that will be exposed to low temperatures, the available output will be less. In these instances, you will need to determine the lowest temperature the battery bank will experience and multiply the *Total Amp-Hours* by the *Multiplier* below.

Temperature	27C/80F	21C/70F	15C/60F	10C/50F	4C/40F	-1C/30F	-7C/20F
Multiplier	1.00	1.04	1.11	1.19	1.30	1.40	1.59

Inverter efficiency: When the inverter is used in a back-up power application the inverter efficiency will not be a large concern. However, if the inverter is the primary AC source for the calculated load, the *Total Amp-Hours* should be multiplied by 1.2 to factor in an average 80% inverter efficiency.

B-6 Battery Wiring Configurations

The battery bank must be wired to match the inverter’s DC input voltage. In addition, the batteries can be wired to provide additional run time. The various wiring configurations:

B-6.1 Series Wiring

Wiring batteries in series increases the battery bank’s output voltage. A series connection combines each battery in a string until the total voltage matches the inverter’s DC requirement. Even though there are multiple batteries, the capacity remains the same. In Figure B-1 below, two 6 VDC/200 Ahr batteries are combined into a single string resulting in a 12 VDC, 200 Ahr bank.

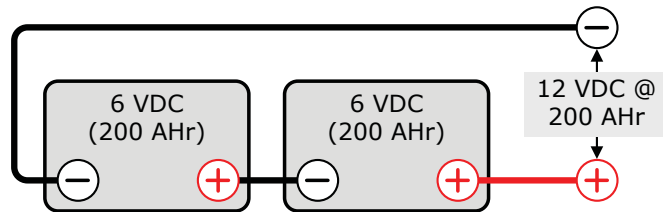

Series Battery Wiring
combines battery voltage:

$$\begin{aligned} &200 \text{ Ahr @ } \underline{6 \text{ VDC}} \\ &+ \\ &200 \text{ Ahr @ } \underline{6 \text{ VDC}} \\ &= \\ &200 \text{ Ahr @ } \underline{12 \text{ VDC}} \end{aligned}$$

Figure B-1, Series Battery Wiring

B-6.2 Parallel Wiring

Wiring batteries in parallel increases the battery bank’s amp-hour capacity, which allows the AC loads to operate for a longer time. A parallel connection combines the number of batteries in the string to increase overall battery capacity; however, the voltage remains the same. In Figure B-2 below, two 12 VDC/100 Ahr batteries are combined into a single 12 VDC, 200 Ahr battery bank.

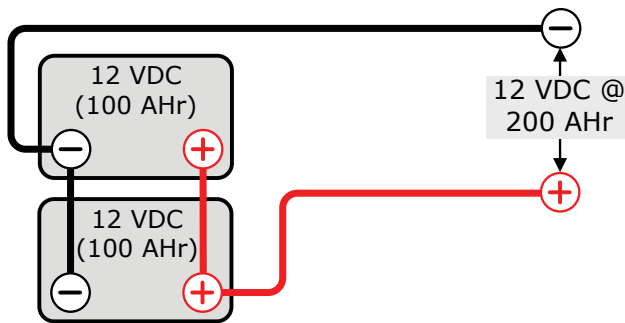

Parallel Battery Wiring
combines battery capacity:

$$\begin{aligned} &\boxed{100 \text{ Ahr}} \text{ @ } 12 \text{ VDC} \\ &+ \\ &\boxed{100 \text{ Ahr}} \text{ @ } 12 \text{ VDC} \\ &= \\ &\boxed{200 \text{ Ahr}} \text{ @ } 12 \text{ VDC} \end{aligned}$$

Figure B-2, Parallel Battery Wiring

B-6.3 Series-Parallel Wiring

A series/parallel configuration increases both voltage (to match the inverter’s DC requirements) and Ahr capacity (to increase run-time for operating the loads) using smaller, lower-voltage batteries. In Figure B-3 below, four 6 VDC/200 Ahr batteries are combined into two strings resulting in a 12 VDC, 400 Ahr battery bank.

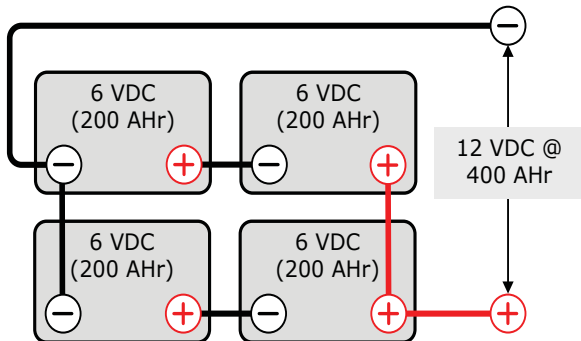

Series/Parallel Battery Wiring

combines battery voltage and capacity:

$$\begin{array}{rcl} 200 \text{ Ahr @ } \underline{6 \text{ VDC}} & & \\ + & & \\ 200 \text{ Ahr @ } \underline{6 \text{ VDC}} & = & \boxed{200 \text{ Ahr}} \text{ @ } \underline{12 \text{ VDC}} \\ & & + \\ 200 \text{ Ahr @ } \underline{6 \text{ VDC}} & & \\ + & & \\ 200 \text{ Ahr @ } \underline{6 \text{ VDC}} & = & \boxed{200 \text{ Ahr}} \text{ @ } \underline{12 \text{ VDC}} \\ \hline \text{add voltage} & & \text{add capacity} \\ \text{in series} & & \text{in parallel} \\ \hline & & = \boxed{400 \text{ Ahr}} \text{ @ } 12 \text{ VDC} \\ & & \text{add voltage and} \\ & & \text{capacity together} \end{array}$$

Figure B-3, Series-Parallel Battery Wiring

Appendix B – Battery Information

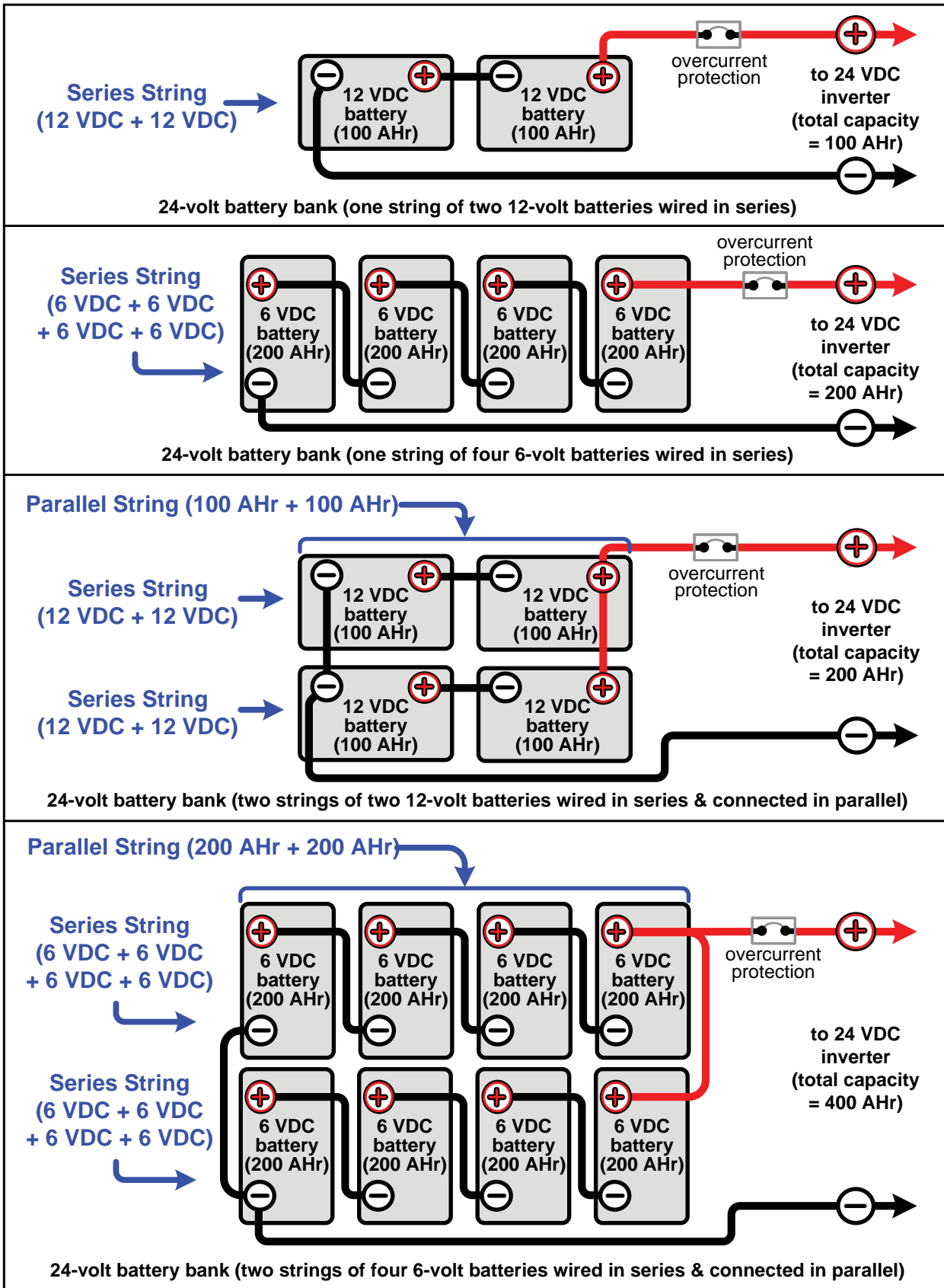

Figure B-4, Battery Bank Wiring Examples (24-volt)

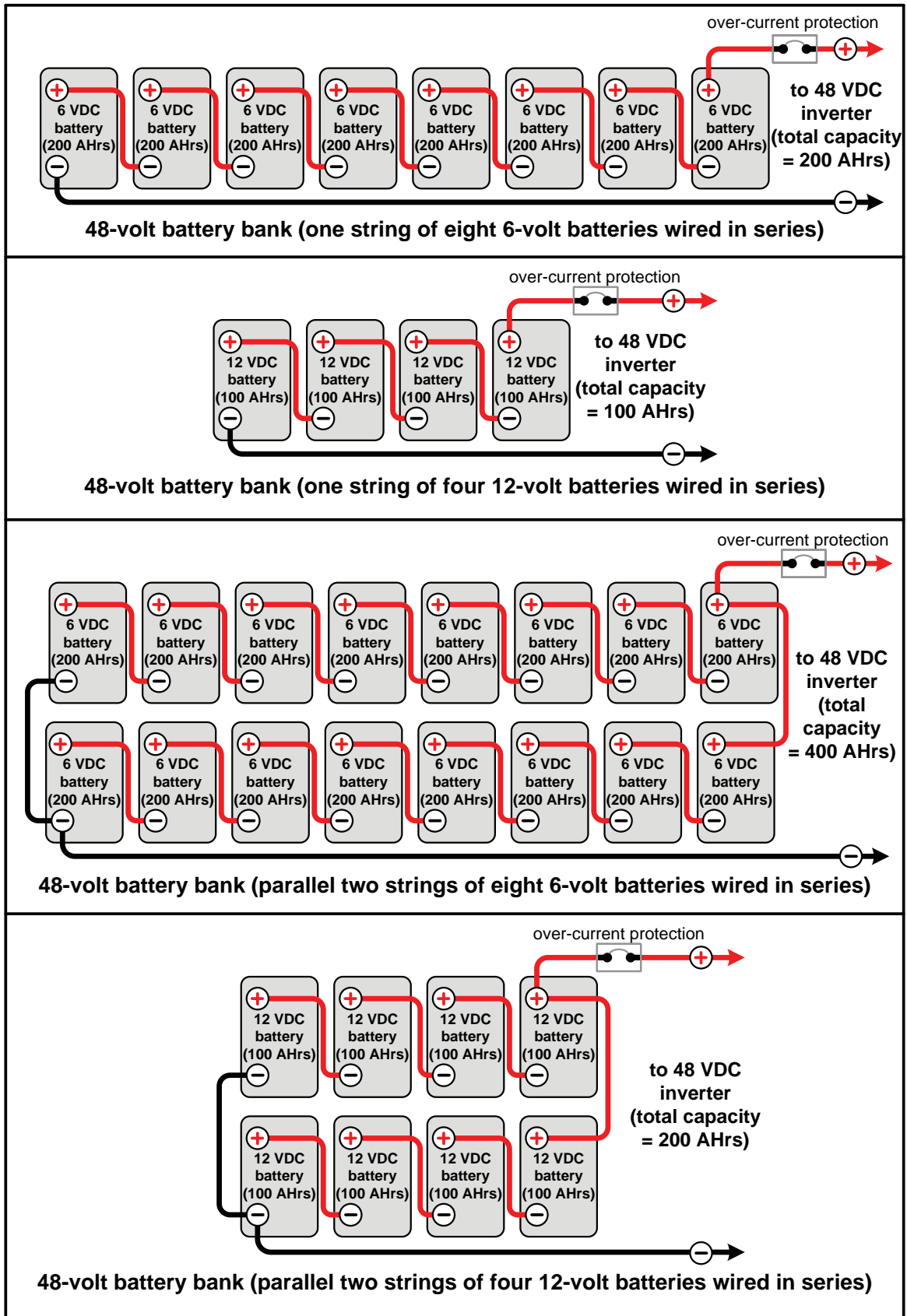

Figure B-5, Battery Bank Wiring Examples (48-volt)

Appendix C – Power Consumption and Output Waveforms

C-1 Appliance Power Consumption

The MS-PE Series inverter/charger can power a wide range of household appliances including small motors, hair dryers, clocks, and other electrical devices. As with any appliance using batteries for power, there is a certain length of time that it can run—this is called “run time.” Actual run time depends on several variables, including the size and the type of appliance, the type of batteries installed in your application, as well as the battery’s capacity and age. Other factors such as the battery’s state of charge and temperature can also affect the length of time your appliances can run. Appliances such as TVs, VCRs, stereos, computers, coffee pots, incandescent lights, and toasters can all be successfully powered by your inverter. Larger electrical appliances, however, such as stoves, water heaters, etc., can quickly drain your batteries and are not recommended for this application. All electrical appliances are rated by the amount of power they consume (see Table C-1). The rating is printed on the product’s nameplate label, usually located on its chassis near the AC power cord. Even though it is difficult to calculate exactly how long an inverter will run a particular appliance, the best advice is trial and error. Your MS-PE Series inverter has a built-in safeguard that automatically protects your batteries from over-discharge.

Table C-1, Typical Appliance Power Consumption

Device	Load	Device	Load	Device	Load
Blender	400W	Coffee Maker	1200W	Light (Flo)	10W
Computer	300W	Color TV	150W	Microwave	1000W
Drill	500W	Hair Dryer	1000W	Light (Inc)	100W
Hot Plate	1800W	Iron	1000W	Refrigerator	500W

C-2 Inverter Output Waveforms

The inverter’s output waveform is the shape of the wave that alternating current makes as its voltage rises and falls with time. Today’s inverters come in three basic output waveforms: square wave, modified sine wave and pure sine wave.

- **Square Wave** – The simplest AC waveform. Some types of equipment behave strangely when powered from a square wave inverter.
- **Modified Sine Wave** – Also referred to as a “quasi sine wave”. This output looks like a one-step staircase and the waveform changes its width to continually provide the correct RMS output voltage regardless of the battery voltage. Most loads that run from a sine wave will also run from a modified sine wave. However, things such as clocks and furnace controllers may have trouble.
- **Sine Wave** – An AC waveform that looks like rolling waves on water. It rises and falls smoothly with time. The grid puts out a sine waveform. Any plug-in AC equipment will operate from a sine wave inverter.

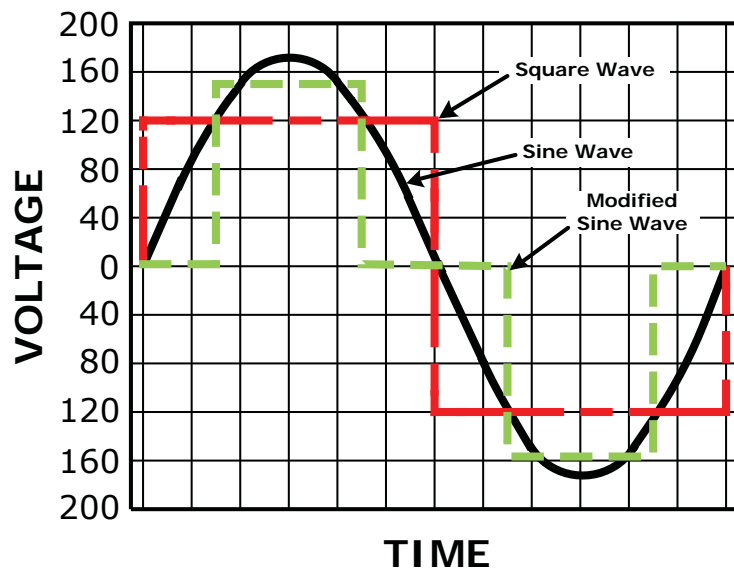

Figure C-1, AC Waveforms

Appendix D – Inverter/Charger Terminology

The following is a glossary of terms with which you may not be familiar. They appear in the various descriptions of inverter and battery charger operation.

Absorption Stage – In this second stage of three stage charging, the batteries are held at a constant voltage (the absorb voltage setting) and the battery is charged to its maximum capacity.

AC (Alternating Current) – Electrical current that varies with time (i.e., utility power). The rate at which the voltage changes polarity is the frequency in Hertz (Hz).

Ampacity – The ampacity of a wire is its current carrying capacity with reference to the cross-sectional area of the conductors, the temperature rating of the insulation and the ambient temperature.

Automatic Transfer Relay (inside the inverter) – An automatic switch that switches between Inverter and Standby mode depending on availability of AC input power. If AC is present, the unit will be a battery charger and pass power through the inverter. When the AC goes away, the unit becomes an inverter.

Bulk Charge Stage – The first stage in three stage charging. In this stage, a constant current is fed to the batteries and as they accept the current the battery voltage will rise.

CEC (Canadian Electrical Code) – The guidelines and acceptable practices for electrical installations in Canada.

Current (Amps) – The amount of electricity flowing through a conductor.

DC (Direct Current) – Electrical current that does not vary with time (i.e., battery voltage).

Deep Cycle – A deep cycle occurs when a battery is discharged to less than 20% of its capacity (80% depth-of-discharge).

Deep Cycle Battery – A battery designed to be routinely discharged to 20% of its maximum capacity without damage. This type of battery is recommended for use with an inverter system.

Derating – As an inverter (or charger) is used above its normal temperature, its capacity to power loads (or charge) continuously is decreased.

Digital Volt Meter (DVM):

True RMS – A voltmeter that incorporates a RMS converter to read true RMS for any waveform shape.

Averaging Type – A voltmeter that requires a sine wave waveform shape to provide an accurate reading.

Efficiency – Usually given as a percentage, efficiency is the ratio of the output to the input. The efficiency changes with power output levels of any inverter.

Electrolyte – Typically a mixture of water and sulfuric acid that is used in lead-acid batteries; it is commonly referred to as battery acid.

Equalization – Controlled “overcharging” of the battery causing it to bubble and mix. This helps reduce stratification.

Float Stage – During the third stage of three stage charging, the voltage and current are reduced to a level that will trickle charge or maintenance charge the battery. This assures the battery remains fully charged even while sitting.

Fuse or Disconnect – When current exceeds a preset limit the fuse or disconnect will fail before the wiring or equipment it is protecting. Disconnects are also called circuit breakers. These are usually reset and can act as a switch to turn off power to equipment for servicing.

Grid (The grid) – Also called the utility grid, this refers to the public power distribution system.

Impedance – Slows the electrical flow of alternating current (AC).

Islanding – The condition present when the utility power grid fails and the inverter attempts to power the grid. An inverter which is “islanding protected” senses the loss of AC power from the grid and does not back feed into the grid system.

Appendix D – Inverter/Charger Terminology

LED (Light Emitting Diode) – A light made up of semi-conducting material.

Line Tie – Term used when the inverter is connected to public power or the “grid” system.

Load(s) – An electrical item that draws power (i.e., lights, radio, refrigerator, etc.,) to work.

Locked Rotor Amps – The current drawn by an electric motor with the shaft or rotor stopped and locked in position. This can be used to determine if an inverter has enough surge current to start a motor. If the inverter is capable of producing more amperage than the locked rotor amps rating of a motor, it will most likely start the motor easily.

NEC (National Electric Code) – The guidelines and acceptable practices for electrical installations in the USA.

Off Grid – Not connected to public power in any way.

Pass Through Current – The amount of current the inverter can safely pass directly from the AC input to the AC output.

Photovoltaic (PV) – Solar powered.

Resistance (Ohms) – Slows the electrical flow of direct current (DC).

RMS (Root Mean Square) – A measure of AC voltage that provides the equivalent heating value across a resistor as would a DC source of the same voltage.

Sellback, or Selling Back To The Grid or Utility-Interactive – Some inverters have the capability to take energy stored in batteries, or from solar panels, and put it back into the utility grid. The local public utility company can compensate you for using this energy.

Shorepower – The process of providing shoreside electrical power to a boat while its main and auxiliary engines are turned off. The source for shorepower may be grid power from an electric utility company, or from an external remote generator.

Stacking:

Series – Two inverters operating together to produce twice the power and voltage of a single inverter. Required when operating 240 VAC loads and separate 120 VAC loads from either inverter.

Parallel – Two inverters operating together to provide twice the continuous capacity on a single output circuit. Required when a single load is too large for one inverter.

Stratification – Over time, a battery’s electrolyte (liquid) tends to separate. The electrolyte at the top of the battery becomes watery while at the bottom it becomes more acidic. This effect is corrosive to the plates.

Sulfating – As a battery discharges, its plates become covered with lead sulfate. During recharging, the lead sulfate leaves the plates and recombines with the electrolyte. If the lead sulfate remains on the plates for an extended period of time (over two months), it hardens, and recharging will not remove it. This reduces the effective plate area and the battery’s capacity.

Temperature Compensation – Peak available battery voltage is temperature dependent. As ambient temperatures fall, the proper voltage for each charge stage needs to be increased. A Battery Temperature Sensor (BTS) automatically re-scales charge-voltage settings to compensate for ambient temperatures.

Voltage – The pressure that causes electrical flow in a circuit.

Watts – Measure of power output or utilization. Watts = Volts x Amps.

Appendix E – Warranty and Service Information

E-1 Limited Warranty

Magnum Energy, Inc., warrants the MS-PE Series inverter/charger to be free from defects in material and workmanship that result in product failure during normal usage, according to the following terms and conditions:

1. The limited warranty for the product extends for 24 months beginning from the product's original date of purchase.

***Note:** The normal 2-year warranty on this MS-PE inverter is extended to 5 years if it was ordered with and installed on a Magnum MP-E or MMP-E panel system. A proof-of-purchase is required at the time of repair/service showing that the MS-PE inverter and the MP-E or MMP-E panel system were purchased at the same time.*

2. The limited warranty extends to the original purchaser of the product and is not assignable or transferable to any subsequent purchaser.
3. During the limited warranty period, Magnum Energy will repair or replace at our option any defective parts—or any parts that will not properly operate for their intended use—with factory new or remanufactured replacement items if such repair or replacement is needed because of product malfunction or failure during normal usage. The limited warranty does not cover defects in appearance, whether cosmetic or decorative, or any structural or non-operative parts. Magnum Energy's limit of liability under this warranty shall be the actual cash value of the product at the time the original purchaser returns the product for repair, determined by the price paid by the original purchaser. Magnum Energy shall not be liable for any other losses or damages.
4. Upon request from Magnum Energy, the original purchaser must prove the product's original date of purchase by a dated bill of sale, itemized receipt.
5. If Magnum repairs or replaces a product, its warranty continues for the remaining portion of the original warranty period or 90 days from the date of the return shipment to the original purchaser, whichever is greater. All replaced products and parts removed from the repaired products become the property of Magnum.
6. This limited warranty is voided if:
 - the product has been modified without authorization
 - the serial number has been altered or removed
 - the product has been damaged from abuse, neglect, accident, high voltage or corrosion
 - the product was not installed and operated according to the owner's manual

E-2 How to Receive Repair Service

If your product requires warranty service or repair, contact either:

Your selling distributor/dealer, an authorized service center listed on the Magnum Energy website at www.MagnumEnergy.com/Service/ServiceCenters-US.htm; or,

Magnum Energy, Inc. at: Telephone: 425-353-8833

Fax: 425-353-8390

Email: Warranty@MagnumEnergy.com

If returning the product directly to Magnum Energy for repair, you must:

1. Return the unit in the original, or equivalent, shipping container.
2. Receive a Return Materials Authorization (RMA) number from the factory prior to the return of the product to Magnum Energy for repair.
3. Place RMA numbers clearly on the shipping container or on the packing slip.

**BEFORE RETURNING ANY UNIT,
A RETURN MATERIAL AUTHORIZATION (RMA) NUMBER IS REQUIRED**



Magnum Energy, Inc.
2211 West Casino Rd.
Everett, WA 98204
Phone: 425-353-8833
Fax: 425-353-8390
Web: www.magnumenergy.com