

Form: 121983C
April 2009

Dimensions

LED Signal Battery Backup System

Installation, Operation and Maintenance Manual

ADI-24Y11

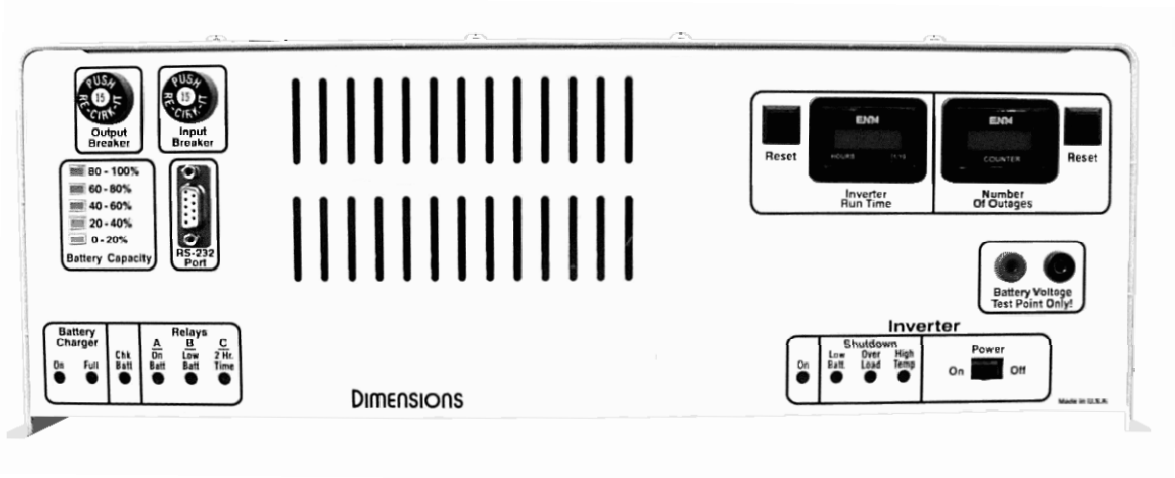

Table of Contents



Section	Description	Page
1.0	Safety Instructions	3
1.1	Warning Symbols	3
1.2	Battery backup System Precautions	3
1.3	Battery Precaution	3
2.0	Specifications	4
3.0	System Physical Description	5
3.1	BBS Physical Description	5
3.2	MBPS 511015 & 30ATR 451036	7
3.3	CMBPS-30ATR 511016-2 (Enclosed case)	8
3.4	CMBPS-30ATR 511016-1 (Open back panel)	8
4.0	Installation	9
4.1	BBS Components	9
4.2	Recommended Useful Tools for Installation	9
4.3	Mounting the BBS	10
4.4	Wiring the BBS	15
4.5	Dry-Relay Contact Wiring	19
5.0	Adjustments	21
5.1	Remaining Battery Capacity Adjustment	21
6.0	Communications	23
6.1	Connecting the RS232 Port	23
6.2	Terminal Setup	23
6.3	Using the BBS Communication Interface	26
7.0	Theory of Operation	28
7.1	System Description	28
7.2	Startup Procedure	31
8.0	Maintenance & Troubleshooting	32
8.1	Preventive Maintenance	32
8.2	Trouble Analysis	33
9.0	Parts List	36
10.0	Electrical Interconnection	37
11.0	Limited Warranty	39

1 Safety Instructions

Important: Read this manual before installation, it contains important safety, installation, and operating instructions. Save this manual and keep it in a safe place.

1.1 Warning and Danger Symbols:

To reduce the risk of electrical shock and to ensure the safe operation of your Dimensions power inverter, the following symbols are used throughout the manual.

ATTENTION:  Important operating instructions. Follow them closely.	DANGER:  Risk of personal harm and/or electrocution exists in this area. Use extreme caution.
---	--

1.2 Battery Backup System (BBS) Precautions:

- BBS produce hazardous voltages. To avoid risk of harm or fire, the unit must be properly installed.
- There are no user serviceable parts inside, do not remove the cover.
- The BBS should not be mounted in a location that may be exposed to rain or spray.
- The BBS should not be installed in a zero clearance enclosure.
- Damage to the BBS will occur if correct polarity is not observed when installing the DC input cables.
- Damage to the BBS will occur if an external AC power source is applied to the inverter's AC hardwire output.
- The BBS contains a circuit breaker and capacitor that may produce a spark. Do not mount in a confined battery or gas compartment.
- Make sure the BBS is turned OFF during installation.

1.3 Battery Precautions:

- Working in the vicinity of lead-acid batteries is dangerous. There is a risk of acid exposure.
- Batteries generate explosive gases during operation.
- There is risk of high current discharge from shorting a battery that can cause fire and explosion. Use insulated tools during installation.
- Remove all rings, watches, jewelry or other conductive items before working near the batteries.
- Inspect the batteries once a year for cracks, leaks or swelling.
- Dispose of the batteries according to local regulations. Do not incinerate batteries; risk of explosion exists.

2 Specifications

ADI-24Y11

Output Voltage: 120 VAC regulated (110 to 125VAC)
Output Frequency: 60 Hz ± 0.05%
Output Waveform: Pure sine wave, less than 3% THD
Input Voltage: (VDC) 21 to 28
Operating Temperature: -37° to 74° C (-35° to 165° F)
Efficiency: Up to 85%



Other Design Features:

- Thermally-controlled cooling fan
- Automatic utility line power bypass when utility line voltage is outside the range of 100 to 130 VAC ± 2 VAC
- Automatic inverter mode dropout when utility line power has been restored above 105 VAC ± 2 VAC for more than 30 seconds
- Lightning surge protection compliant with IEEE 587/ANSI C.62.41
- Completely connectorized system
- LED for Inverter Power, Low Battery, High Temp, & Overload
- LED for Battery Charger On & Full plus Check Batteries
- LED Battery Voltage Indicator & Voltage Test Points
- LED for Relay A (On Batt), Relay B (Low Batt), and Relay C (2 hour Time)
- Two terminal blocks provide access to BBS Form C dry relay contacts
- Low Batt voltage threshold (Relay B) is adjustable
- Inverter Run Time Meter w/reset
- Inverter Event Counter Meter w/reset

Unit Protection:

- Automatic electronic short circuit/overload protection
- Automatic over temperature shutdown
- Input and Output circuit breakers

Battery Protection:

- Automatic low battery shutdown at 21 VDC
- In-line battery cable fuse
- Remote temperature sense cable
- Temperature compensated battery charging system - shuts off over 50°C (122°F)

Communication:

- RS232 Communication port provides local programming, system alarms and download of event buffer via windows based PC.

BBS MODEL NUMBER: ADI-24Y11	LED Status light on front wiring connectors at the back
Output Power (Watts Continuous)	1,100 @ 25°C (77°F), 700 @ 74°C (165°F)
Output Current (Amps AC)	Up to 9
Peak Output (Amps AC)	37
Input Current (Amps DC)	Up to 55
Weight (Lbs.)	42
Dimensions (WxDxH) (inches)	16½ x 12 x 6
BATTERY CHARGER	
Output Voltage (Volts DC)	Regulated and temperature compensated end of charge at 27.6
Output Current (Amps DC)	Up to 13
Input Current (Amps AC)	Up to 7
TRANSFER RELAY	
Current Rating (Amps AC)	15
Transfer Time (milliseconds)	40 typical

- **Usage:** All 170, 2070 traffic equipment within the inverter's power rating.
- **Warranty:** Two year parts and factory labor with **Advance Replacement Program**

3.1 BBS Physical Description

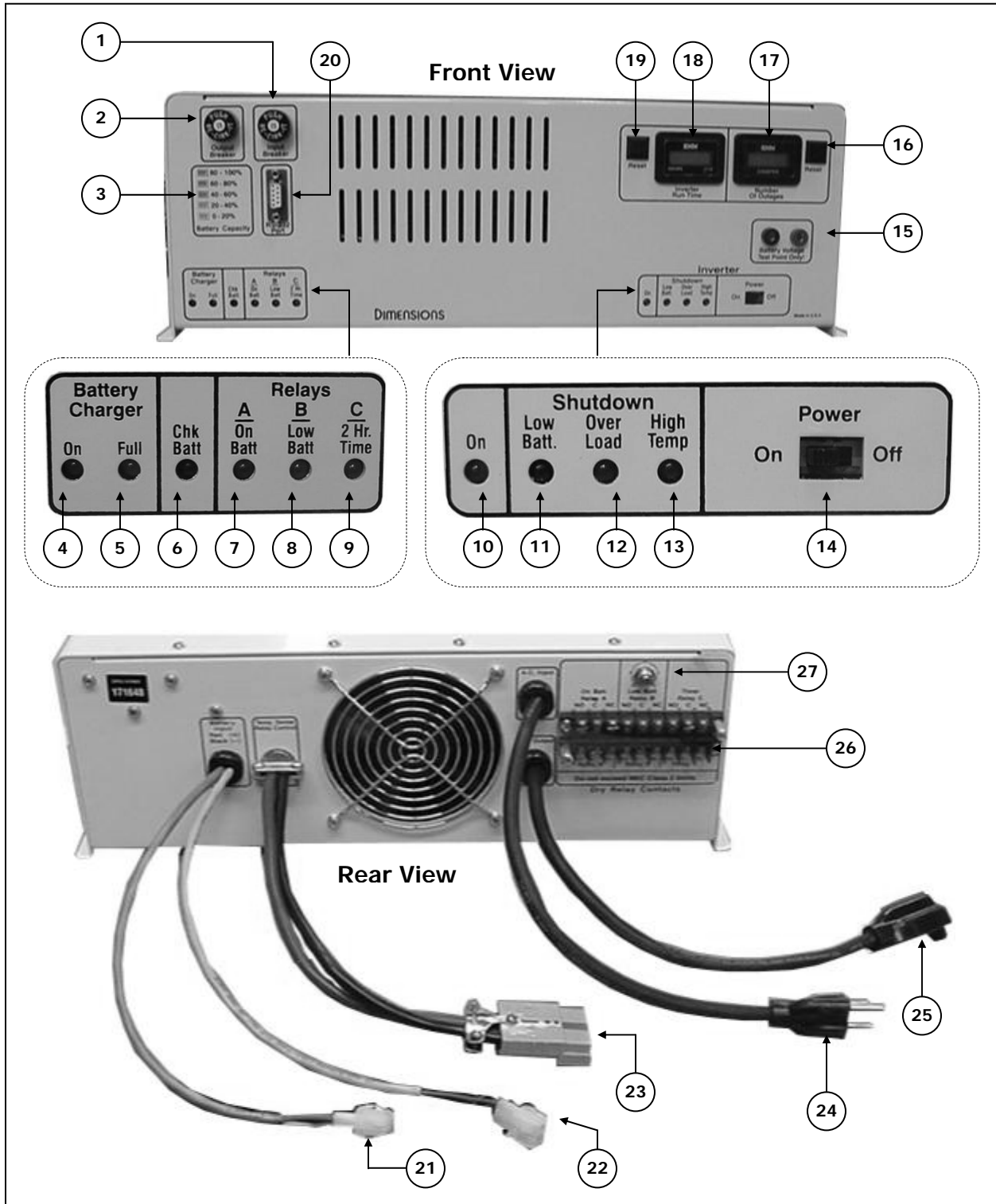

FIGURE 1: BBS Module model ADI-24Y11 physical description front and rear view

- (1) **Input Breaker:** Trips to protect utility power from a BBS short circuit.
- (2) **Output Breaker:** Trips to protect the BBS from a load short circuit.
- (3) **Battery Capacity:** Indicates a ratio of battery capacity level.
- (4) **Battery Charger On:** The green LED lights only when external AC power is present to indicate that the battery charging is engaged.
- (5) **Battery Charger Full:** The green LED lights only when external AC power is present to indicate that batteries are fully charged.
- (6) **Check Battery:** Yellow LED indicates a problem in the batteries or the battery cable.
- (7) **Relay A – On Batt:** Green LED lights to indicate that the BBS is in Inverter mode.
- (8) **Relay – B – Low Batt:** Green LED lights when the system is in Inverter mode and the useful battery capacity remaining is at the reference level chosen by user (40% in most applications).
- (9) **Relay – C – 2 Hr. Time:** Lights only to indicate that the BBS has been in Inverter mode for more than two hours.
- (10) **Inverter On:** Green LED lights only if the power switch has been set to “On” to indicate that the DC to AC inverter is on.
- (11) **Inverter – Shutdown – Low Batt:** Red LED lights to indicate that the battery voltage has dropped to 21VDC and will shutdown in five seconds due to a low voltage condition.
- (12) **Inverter – Shutdown – Overload:** Red LED lights to indicate that the power demand by the load is larger than the power the BBS can deliver. The inverter will shutdown in five seconds due to an overload condition.
- (13) **Inverter – Shutdown – High Temp:** Red LED lights to indicate that the internal electronic circuit temperature has exceeded the maximum operating temperature limit. The inverter will shutdown in five seconds due to a high temperature condition.
- (14) **Power On/Off Switch:** Turns the inverter “On” or “Off” and activates or deactivates the dry relay contacts as well.
- (15) **Battery Voltage Test Point:** Attach voltmeter probes to check the battery voltage at the inverter.
- (16) **Meter Reset Button – Number of Outages:** Push to reset the inverter Number of Outages Meter.
- (17) **Number of Outages Meter:** Tells the number of times the system has operated from batteries since the meter was reset.
- (18) **Inverter Run Time Meter:** Tells the total time the system has operated from batteries since the meter was reset.
- (19) **Meter Reset Button – Run Time Meter:** Push to reset the inverter run time meter.
- (20) **RS-232 Connector Port:** Connects to a windows based PC for monitoring and controlling the BBS.
- (21) **Transfer Relay Connector:** Two-pin connector connects to the 30ATR or CMBPS-30ATR to drive the 30 amps relay.
- (22) **Temp. Comp. Sense Wire:** Three-pin connector connects to a 9ft extension wire to the negative battery post.
- (23) **Battery Connector Cable:** Enables fast connection to batteries, Red (+) and Black (-) marks.

- (24) **BBS AC Connector Plug:** Connects to the 30ATR or CMBPS-30ATR receptacle cord item 33 in Figure 2 below.
- (25) **BBS AC Receptacle Cord:** Connects to the 30ATR or CMBPS-30ATR AC plug item 32 in Figure 2 below.
- (26) **Dry Relay Connector Board:** Wiring connector board
- (27) **Low Battery Voltage Potentiometer:** Use to select the level of remaining useful battery capacity to trigger the low battery dry relay.

3.2 MBPS 511015, 30ATR 451036 or 451036-1:

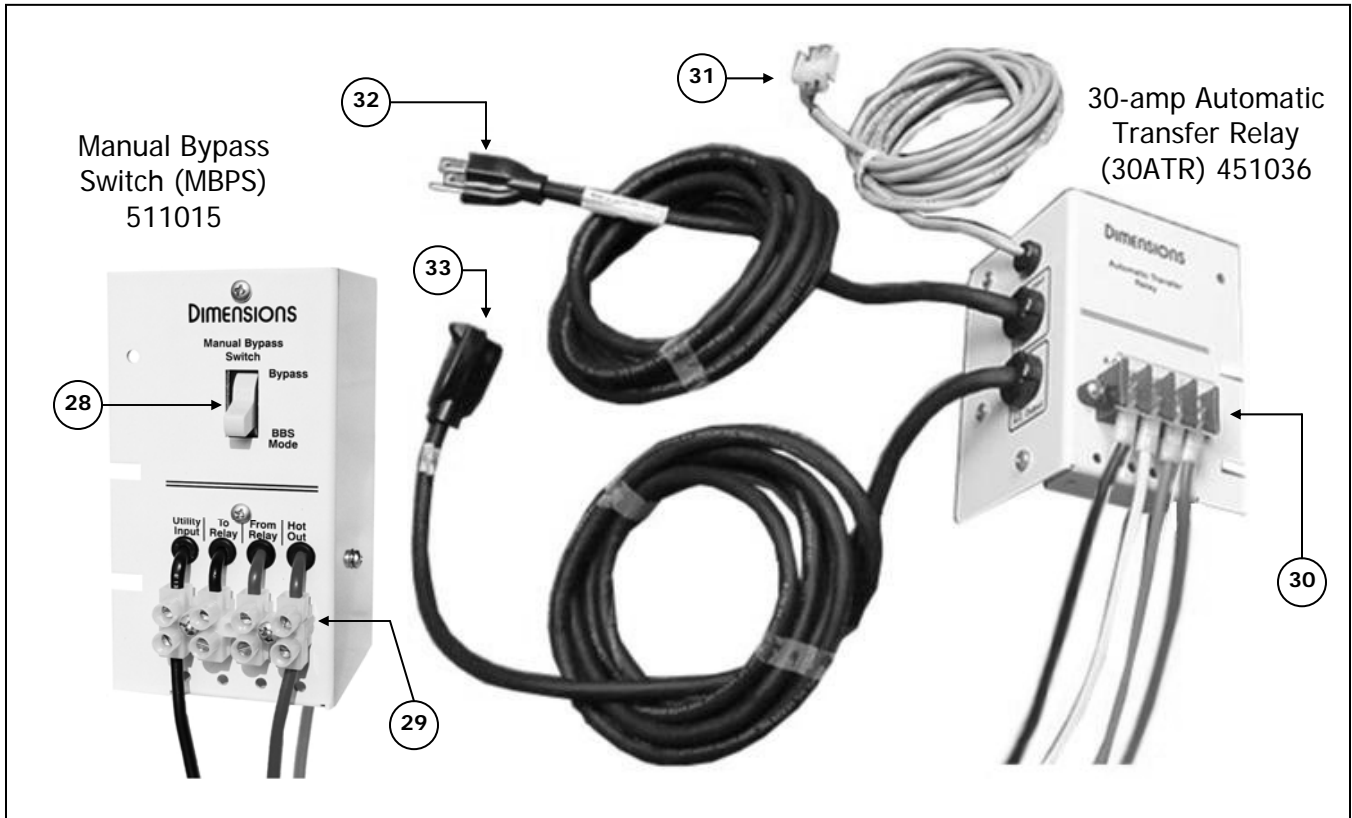

FIGURE 2: MBPS 511015 and 30ATR (right mount) physical description

Note: 30ATR 451036 right mount and 451036-1 left mount

- (28) **Bypass – BBS mode Switch (MBPS):** Used to isolate the BBS system from external AC power during routine maintenance.
- (29) **Terminal Connector Board (MBPS):** AC Wiring connector board
- (30) **Terminal Connector Board (30ATR):** AC Wiring connector board
- (31) **Transfer Relay Connector (30ATR):** Connects to item (21) on Figure 1, page 5 to drive the 30-amp relay.
- (32) **A.C. Input Plug Cord (30ATR):** Connects to item (25) on Figure 1, page 5
- (33) **A.C. Output Outlet Cord (30ATR):** Connects to item (24) on Figure 1, page 5

3.3 CMBPS-30ATR 511016-2 (enclosed case)

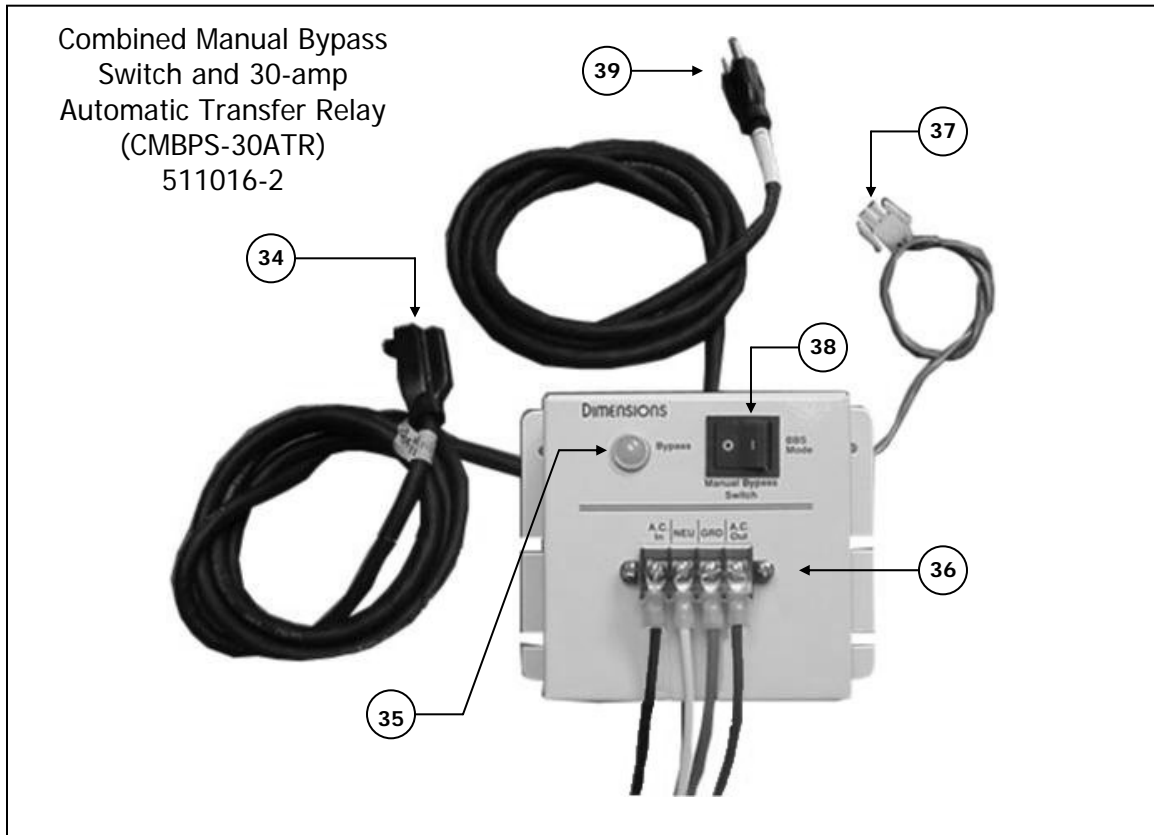

FIGURE 3: CMBPS-30ATR enclosed case physical description





- (34) **AC Outlet Cord:** Connects to item (24) on Figure 1, page 5
- (35) **Indicator Light:** Lights to indicate the switch is in the bypass mode.
- (36) **Terminal Connector Board:** AC Wiring connector board
- (37) **Transfer Relay Connector (30ATR):** Connects to item (21) on Figure 1, page 5 to drive the 30-amp relay.
- (38) **Bypass Switch:** Used to isolate the BBS system from external AC power during routine maintenance.
- (39) **AC Input Plug Cord:** Connects to item (25) on Figure 1, page 5

3.4 CMBPS-30ATR 511016-1 (Open back panel)

The physical description is the same as the enclosed case 511016-2 they both have the same features and accomplish the same function.

4.1 BBS Components:

TABLE 1

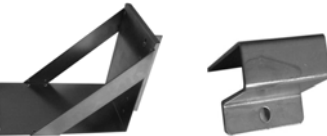
Picture	Part Number and Description	Qty.
	<p>The BBS module ADI-24Y11 fits most of the 170/2070 controller cabinets. All the lead wires and connectors are at back of the BBS module for easy access from the rear door.</p>	<p>1</p>
	<p>BBS mounting brackets right side 140272 and left side 140273. Washers 250275 and Screws 250274 are included. Used for 170/2070 in cabinet mounting.</p>	<p>1 Each as required</p>
	<p>Combined Manual Bypass Switch – 30A Automatic Transfer Relay 511016-1 (open back panel) or 511016-2 (enclosed case) Used on standard applications. Washers 250275 and Screws 250274 are included.</p>	<p>1</p>
	<p>Two piece configuration requires a separate stand-alone manual bypass switch part number 451036 right mount or 451036-1 left mount and a 30A transfer relay part number 511015. Washers 250275 and Screws 250274 are included.</p>	<p>1 Each</p>
	<p>12 VDC, 79 AH Group 24 AGM batteries 390003 or 12 VDC 105 AH group 31 batteries 390006 are available. One quick connector battery cable kit included.</p>	<p>2 or 4 Each</p>
	<p>Swing-out battery shelves 141217-1 fits 390003 batteries, 141226-1 shelves fits 390006 batteries. Battery shelf clips 140227 are included in both cases. Washers 250275 and Screws 250274 are included.</p>	<p>2 or 4 Each</p>

Check your packing slip against Table 1

4.2 Recommended Useful Tools for Installation:

Butt type and insulated connector, drill, Crimpers (for insulated and non-insulated connectors), Digital Volt Meter with probes, Electrical Tape, #2 Phillips Screwdriver, Socket Wrench, Wire cutters, Wire strippers, Cable ties, Tape measure.

4.3 Mounting the BBS

4.3.1 Mounting the BBS Module:

- 1) **Shelf Mounting:** Mounting brackets are not required.
 - a) Locate the keyholes at the right and left side of the chassis flanges. See BBS module footprint on Figure 5 below.
 - b) Screw or bolt the keyholes using $\frac{1}{4}$ inch diameter screws.
 - c) Make sure the BBS is firm and secure.
- 2) **Rack Mounting:** Mounting brackets required.
 - a) Secure the two mounting brackets with the screws and washers provided, on the vertical mounting surface chosen.
 - b) Place the BBS over the flanges of the two mounting brackets. See Figure 4 below.

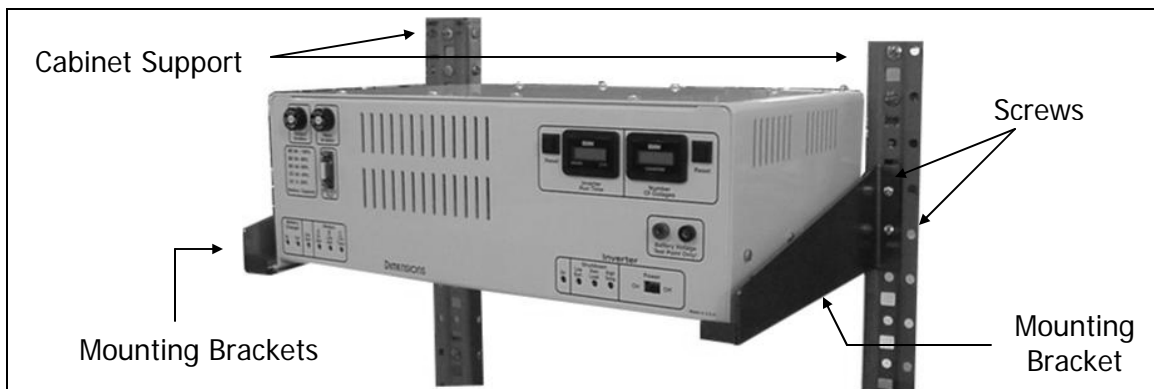

FIGURE 4: Rack mounting

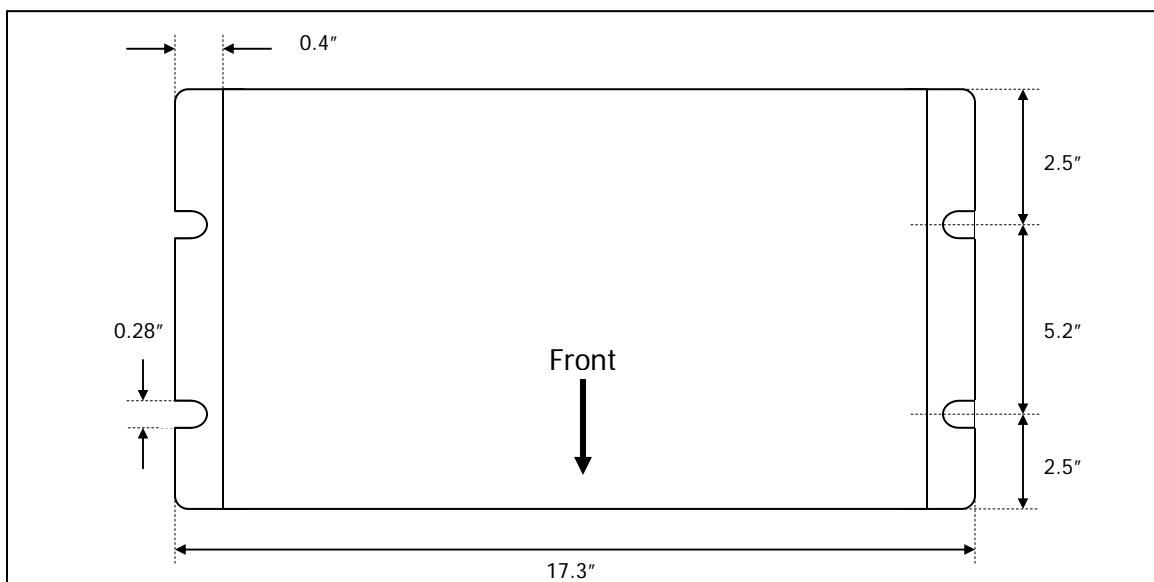

FIGURE 5: BBS Module footprint

4.3.2 Mounting the Manual Bypass Switch and the 30A Transfer Relay

- Locate the cabinet support (Rack mounting – check for right or left mounting) or shelf (Shelf mounting)
- Using the washer and bolt provided fix the 30A transfer relay and the combined manual bypass switch as shown on Figures 6, 7 and 8 below.

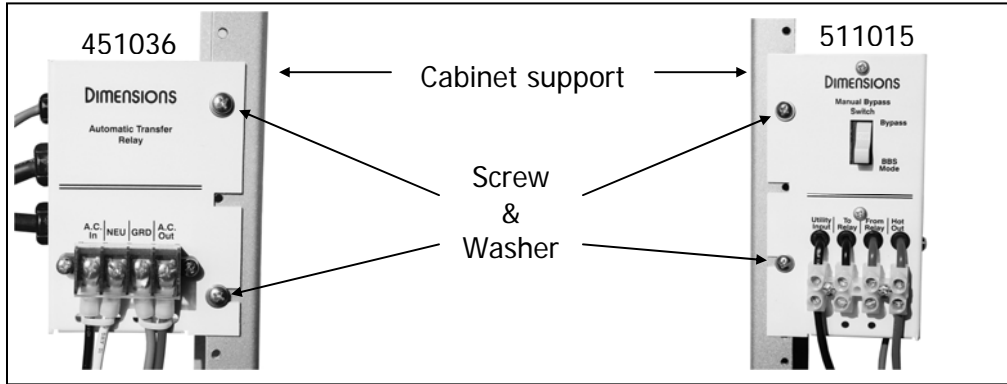

FIGURE 6: Mounting the MBPS and 30ATR

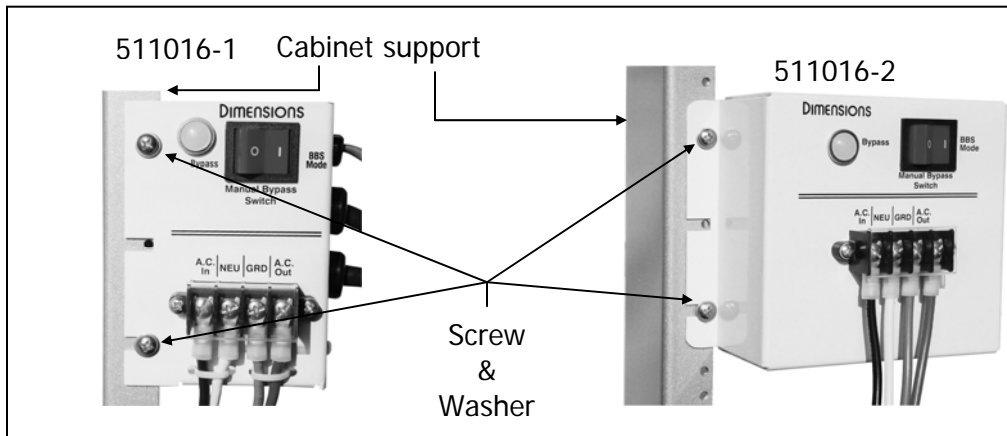

FIGURE 7: Mounting the CMBPS-30ATR open and closed frame

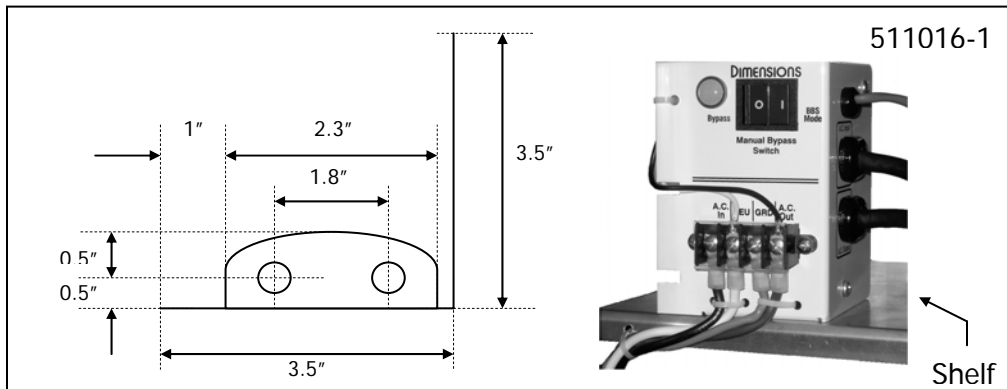

FIGURE 8: CMBPS-30ATR open frame shelf mounting and footprints

4.3.3 Mounting the Swing-out Battery Shelves

- Locate the vertical cabinet support column at the back of your cabinet on the rear door. See Figure 9 below
- Using six screws and washers, attach each swing out battery shelf hinge-mounting surface to the front of the vertical cabinet support. Space the swing out battery shelves at 12" from bottom to bottom. See Figure 11, page 14.
- To prevent accidental movement of each swing out battery shelf, install the metal holding clip provided. Slide the clip fully down over the top of the hinge at the vertical surface of the swing out battery shelf.

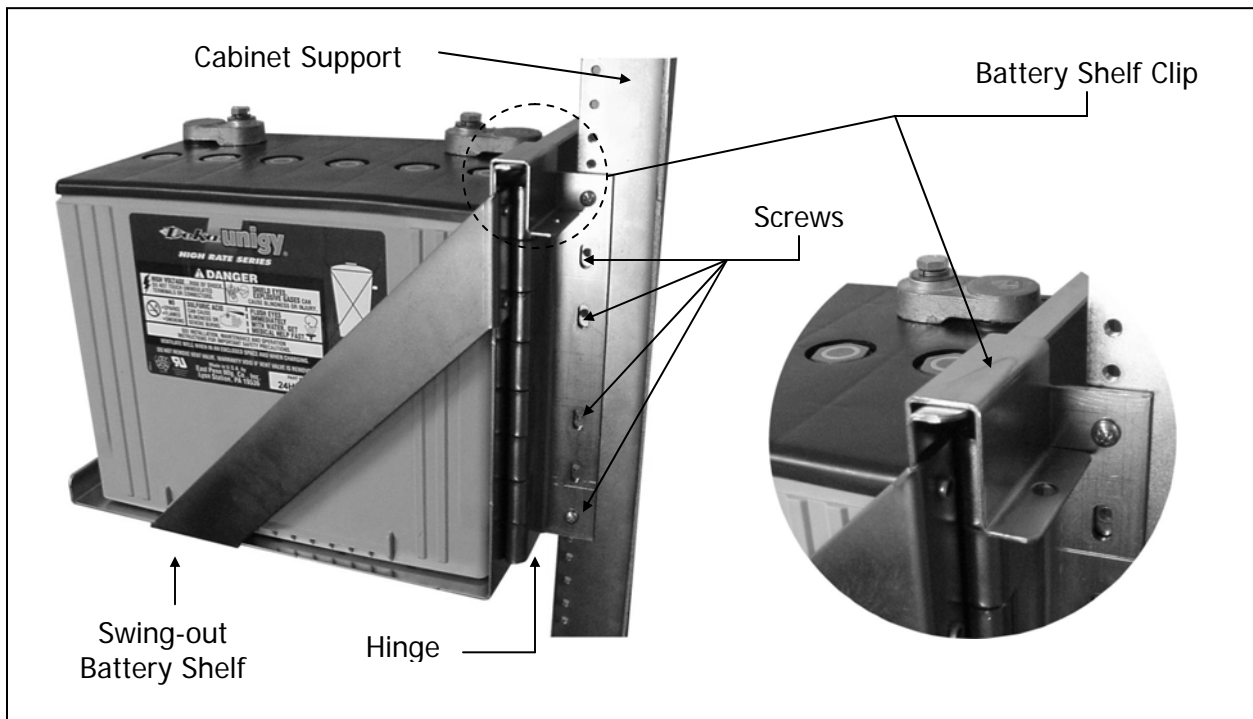

FIGURE 9: Mounting the swing-out battery shelves

4.3.4 Mounting the Batteries



Warning: Connecting the BBS incorrectly to the battery will cause damage that is not covered under warranty.

- Place one battery on each shelf with the negative terminal next to the hinge.
- Connect the red wire to the positive post of the first battery using one set of the four-battery quick connector wire set provided.
- Connect the black wire to the negative post of the same first battery.
- Repeat procedure on the second, third and fourth battery respectively.
- Plug the four quick connectors as shown on Figure 10 on page 13.
- Finally, plug the main quick Anderson connector and check the tightness of all connections.

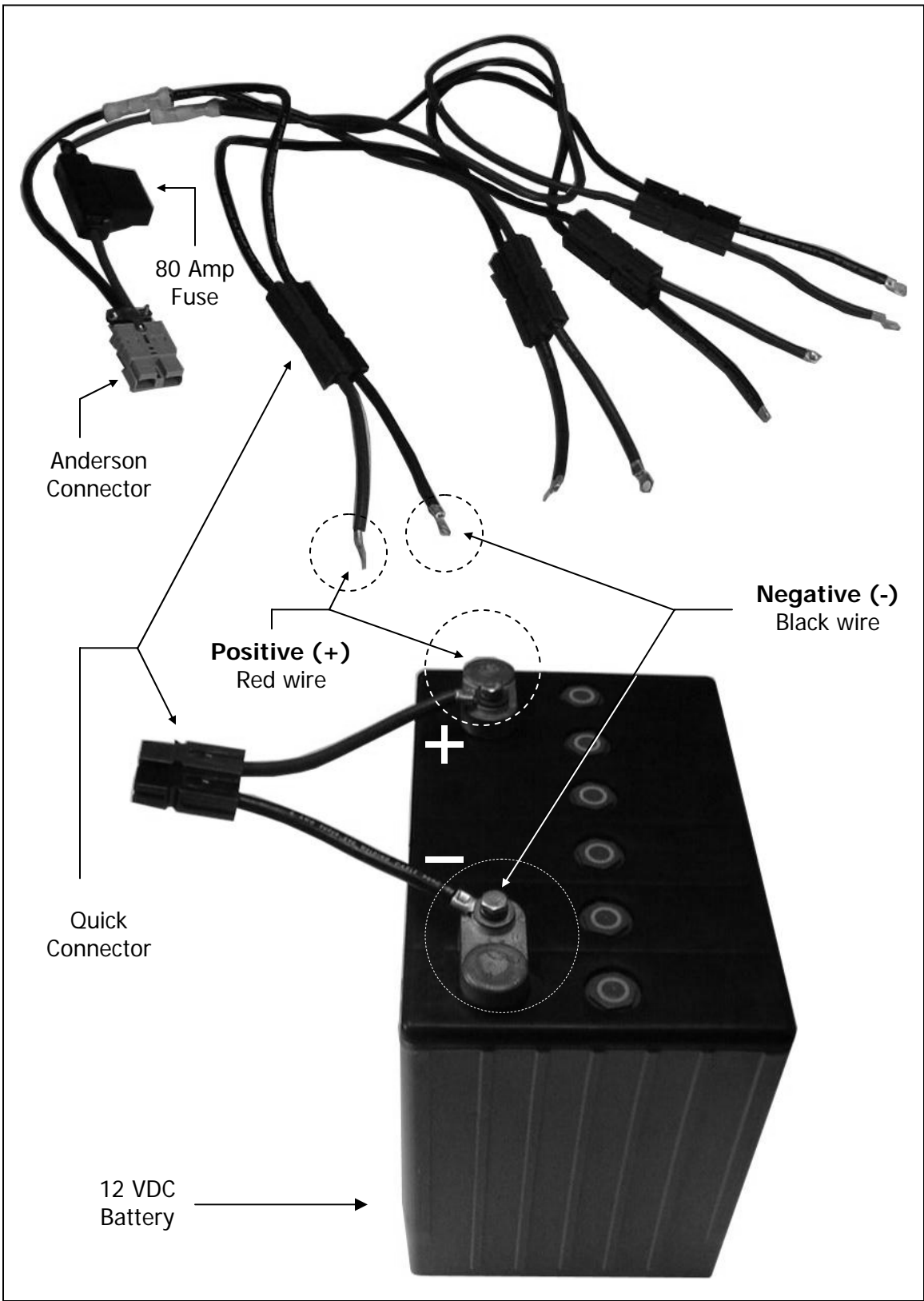

FIGURE 8: Absorbent Glass Mat (AGM) battery and quick connector battery cable

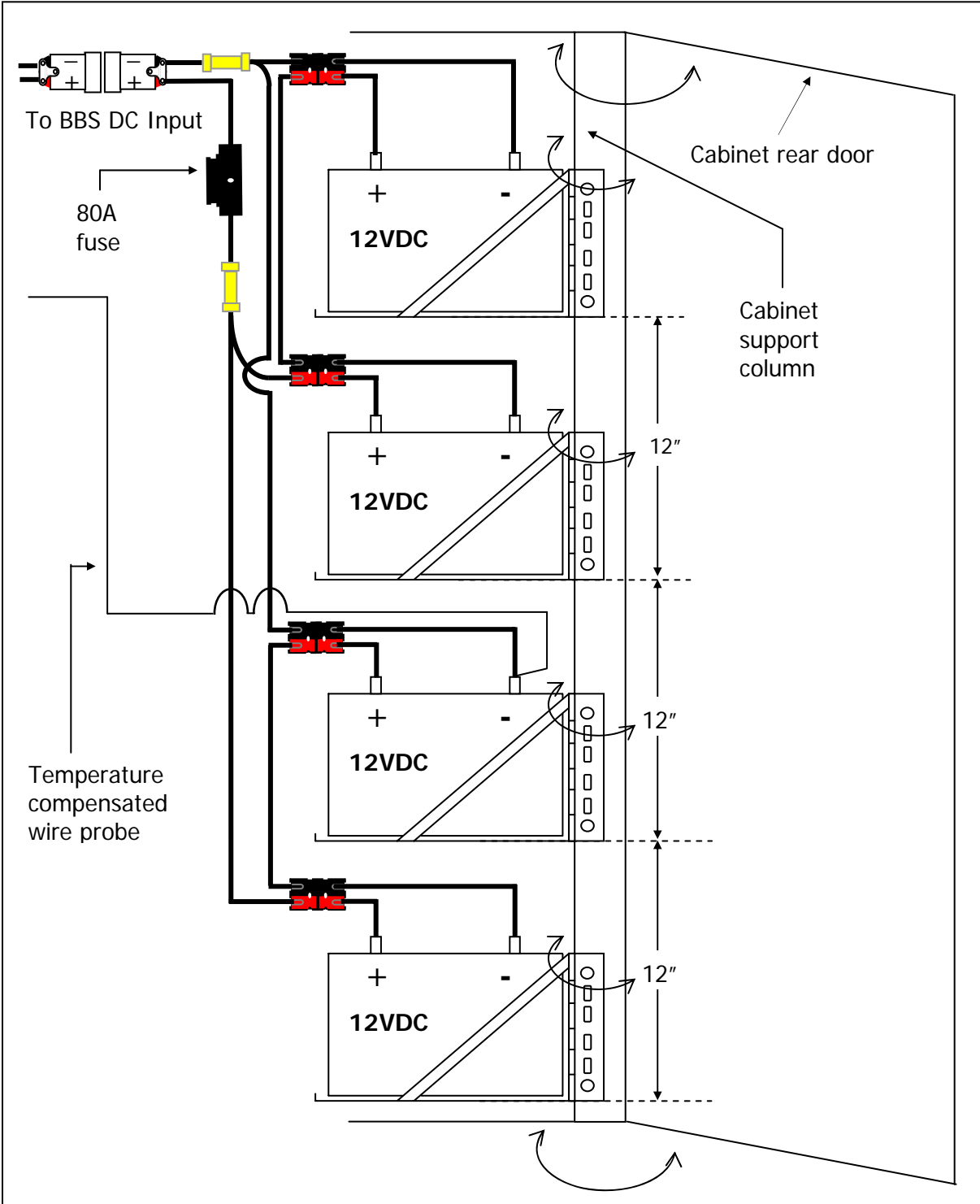

FIGURE 11: Battery wiring configuration

4.4 Wiring the BBS

4.4.1 BBS Module Wiring

- 1) **Grounding:** No grounding connection required.
- 2) **External temperature compensation battery charger:** The temperature-compensated battery charging system compensates over a range of 2.5 – 4.0 mV/°C per cell. The temperature sensor is external to the inverter/charger unit and comes with 2 meters (6'6") of wire (3 meters or 9'9" for Caltrans units).



Batteries shall not be recharged when battery temperature exceeds 50°C (122°F)

NOTE: Connect the 5/16" ring, 2-gauge temperature compensated sense wire probe coming out from the BBS module to the battery return (negative battery bank post). See Figure 11 on page 14 or Figures 28 and 29 on pages 37 and 38 respectively.

- 3) **30A AC Transfer Relay connector plug:** Plug the male two-pin connector 30A automatic transfer relay drive wire (red and black) coming out from the BBS module into the female two-pin connector wire (red and black) coming out from the 30A Automatic Transfer Relay. See Figures 12 and 13 on pages 16 and 18.

4.4.2 MBPS 511015 and 30ATR 451036 Wiring:



Risks of electrocution exists make sure that the BBS and the external power line are turned "Off" before wiring.

- a) Mount the 30ATR and the MBPS in the cabinet. Toggle the MBPS to "Bypass", isolating the BBS from all AC inputs.
- b) Use the 10-foot long 10-gauge wires that are supplied for all connections between the controller terminal block, MBPS and the 30ATR. Use the existing utility feed wire when connecting to the MBPS.
- c) Disconnect the A.C. external AC power hot (black) wire entering the cabinet and connect it to the MBPS terminal labeled "Utility Input".
- d) Connect the 10-gauge. wire that is attached to the 30ATR terminal labeled "A.C. In" to the MBPS terminal labeled "To Relay".
- e) Connect the 10-gauge wire that is attached to the 30ATR terminal labeled "A.C. Out" to the MBPS terminal labeled "From Relay".
- f) Connect the 10-gauge wire that is attached to the MBPS terminal labeled "Hot Out" to the cabinet external AC power input connection point disconnected in (c).
- g) Connect the white 10-gauge wire that is attached to the 30ATR terminal labeled "NEU" to the cabinet external AC power neutral buss.
- h) Connect the 30ATR and the MBPS green ground wires to the cabinet external AC power ground buss.
- i) Connect the AC cord with plug from the 30ATR to the BBS AC receptacle cord.
- j) Connect the 30ATR quick connector plug to the BBS relay quick connector plug.
- k) Connect the AC cord with plug from the BBS to the AC receptacle cord from the 30ATR.
- l) Turn the external AC power "On", the BBS module to "On" and the MBPS to "BBS Mode".

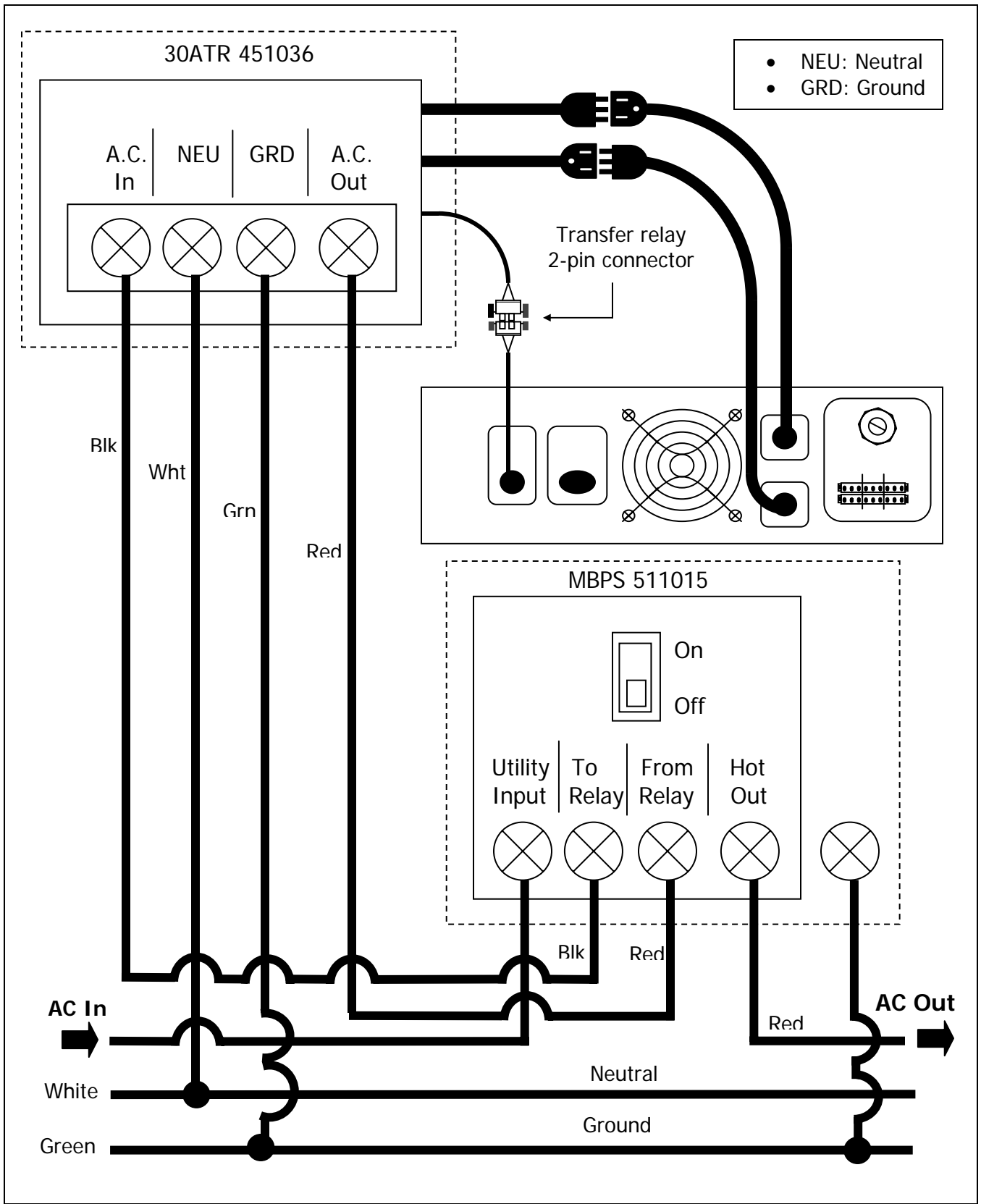

FIGURE 12: AC wiring configuration MBPS and 30ATR

4.4.3 CMBPS 511016-1 or 511016-2 Wiring

- a) Make sure the BBS and the A.C. utility line are turned "Off".
- b) Mount the combined Manual Bypass Switch-30A Transfer Relay in the cabinet. Toggle the Manual Bypass Switch to "Bypass Mode" to isolate the BBS from all AC inputs.
- c) Use the 6½-foot long 10-gauge wires that are supplied for all connections between the controller terminal block and the combined Manual Bypass Switch-30A Transfer Relay. Use the existing utility feed wire when connecting to the combined Manual Bypass Switch - 30A Transfer Relay.
- d) Disconnect the A.C. utility line hot (black) wire entering the cabinet. Using the supplied red wire nut, connect the A.C. utility line hot (black) wire to the black 10-gauge wire that is connected to the Combined Manual Bypass Switch - 30A Transfer Relay terminal labeled "A.C. In".
- e) Connect the red 10-gauge wire from the Combined Manual Bypass Switch-30A Transfer Relay terminal labeled "A.C. Out" to the cabinet A.C. utility line hot terminal disconnected in section (d).
- f) Connect the Combined Manual Bypass Switch-30A Transfer Relay neutral and ground wires to controller grid neutral and ground buss lines respectively.
- g) Connect the A.C. cords with plug and receptacles coming out from the Combined Manual Bypass Switch-30A Transfer Relay into the BBS matching receptacle and plug cords respectively.
- h) Connect the Combined Manual Bypass Switch-30A Transfer Relay quick connector plug to the BBS relay quick connector plug.
- i) Turn the utility grid "On" and the Combined Manual Bypass-30A Transfer Relay red switch to "BBS Mode". The battery charger will automatically start and operate whenever grid power is present.
- j) Turn the inverter to "On". It will activate when grid power is lost.

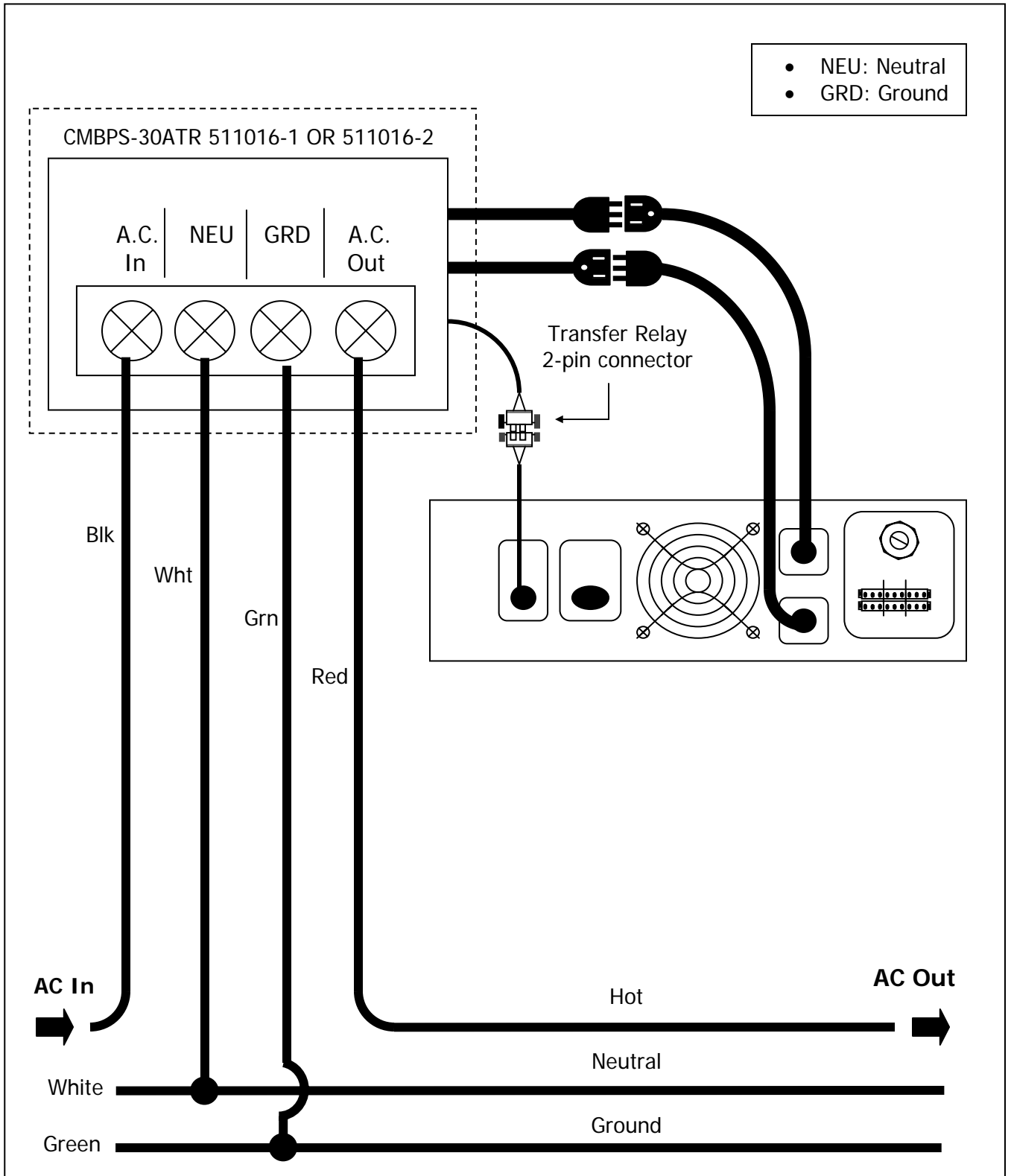

FIGURE 13: Wiring configuration CMBPS-30ATR

4.5 Dry-Relay Contact Wiring

For units purchased by Caltrans, this section is not to be used, please follow the Caltrans wiring documentation for relay connections.



Risk of electrocution may exist when working with the dry relay contacts. Please turn the BBS "Off", make sure the manual bypass switch is set to "Bypass" position and take the 80A fuse out of the fuse-holder. Place the 80A fuse back into the fuse-holder when done.

4.5.1 Wiring Recommendations- On Batt-Relay A:



This relay connection provides a means for the controller to indicate that the Utility Power is either down or unqualified at this intersection. This relay may also be used as a flash operation switch; however, using it in this manner will eliminate full run time operation. This is useful when incandescent bulbs are still present driving the full operation current consumption over 6.5 amps. Refer to Section 7 for wiring flash operation. See figure 14 on page 20.

- a) Locate an unused Alarm input on the 170/2070 Input File.
- b) Using a pair of the multicolor wires supplied with the BBS, connect the spade end to the "On Batt" relay connector A.
- c) Connect the loom end of the wires to the Alarm input chosen in line (a)
- d) Follow the Controller manufacturers instructions for Alarm reporting on the Alarm input that was chosen in line (a) above.

4.5.2 Wiring Recommendations- Low Batt-Relay B:



Low Batt-Relay B may also be used as another Alarm function via Controller input or via pager module to notify personnel that the intersection will need attention because of a low voltage condition. It is possible to use Relay B in parallel with Relay C to provide flash operation if the BBS has been in Inverter mode for 2 hours or the batteries reach the capacity set in Section 5.1, whichever comes first. See figure 14 on page 20 for red flash wiring connection.

- a) Identify the manual red flash switch circuit in the Controller cabinet-wiring diagram and locate the manual red flash switch in the traffic light controller cabinet.
- b) Using a pair of the multicolor wires supplied with the BBS, connect the spade end to the relay connector B.
- c) Connect the loom end of the wires to the manual red flash switch pole.

4.5.2 Wiring Recommendations- Timer-Relay C:



Timer-Relay C may also be used as another Alarm function via Controller input or via pager module to notify personnel that the intersection will need attention if the BBS has been in Inverter mode for 2 hours or more. See figure 14 on page 20 for red flash wiring connection.

- a) Using a pair of the multicolor wires supplied with the BBS, connect the spade end to the relay connector C.
- b) Connect the loom end of the wires to the manual red flash switch pole.

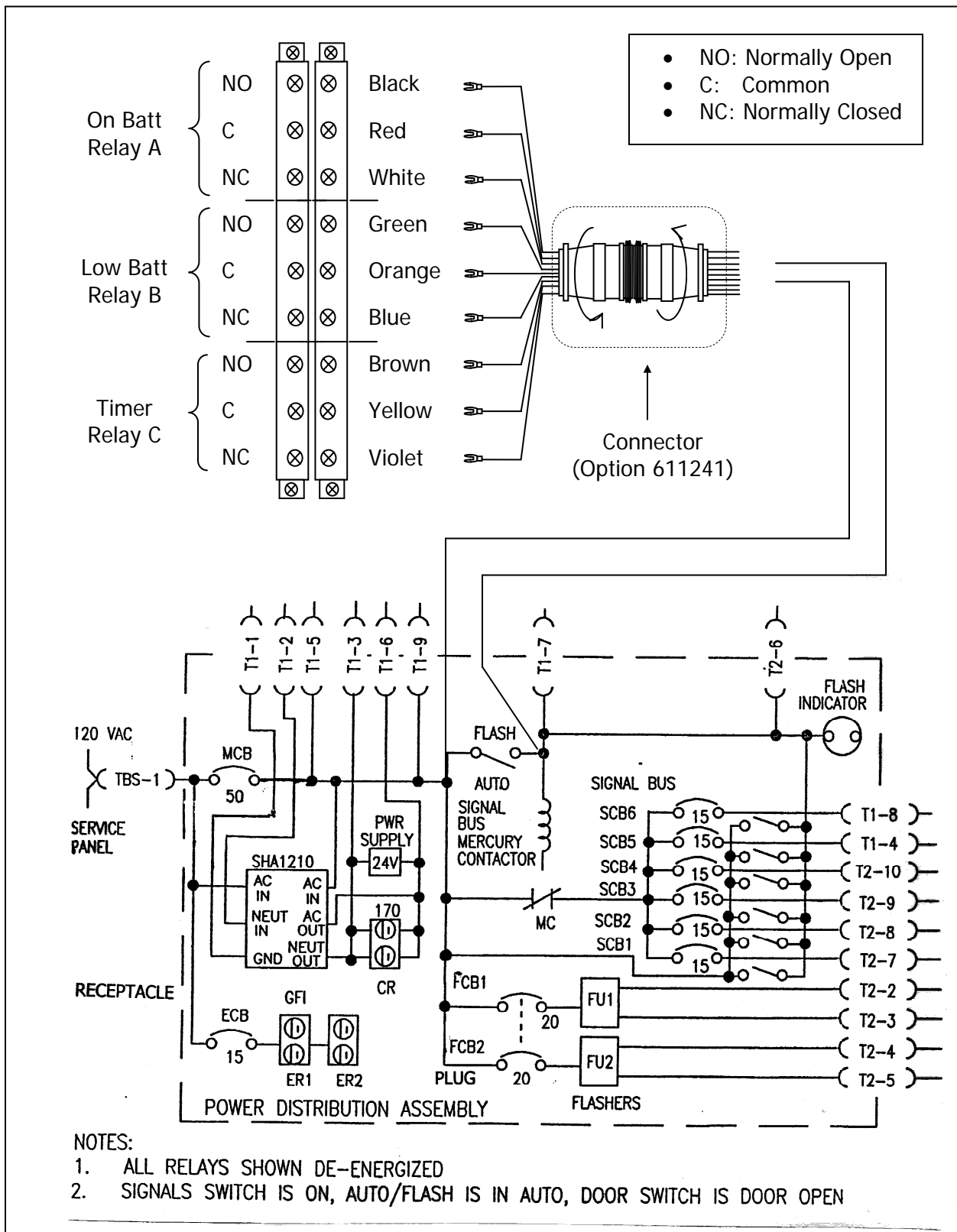

FIGURE 14: Red Flash wiring configuration

5.1 Remaining Battery Capacity Adjustment

5.1.1 40% Useful Remaining Battery Capacity Adjustment

The BBS module supplies full power backup until the battery capacity is depleted. The battery voltage will be at 21 VDC and the BBS module will automatically shut off with a "low battery" indication. Battery damage will be prevented.

The "Relay B – Low Batt." dry contact output can be used as a signal to activate a flasher/beacon or switch the intersection traffic light controller to Red Flash mode when the amount of battery capacity left is low, but not depleted. Since Red Flash mode consumes significantly less power than full operation does in intersections with both incandescent and LED lamps, switching the intersection to Red Flash will allow the intersection to continue to operate during long grid power outages. In typical applications 40% is the chosen point to trigger anything connected to the "Relay B – Low Batt." dry contacts. Red Flash mode wiring is shown on Figure 13.

5.1.2 Adjusting the "Relay B – Low Batt." potentiometer:

Note: Potentiometer Position A is fully counterclockwise (CCW), position E is fully clockwise (CW). The values in Table 2 are based on BBS's with a total battery capacity of 158 AH (4-79 AH batteries).

The potentiometer can be set to any point of useful battery capacity remaining from 2% to 99% as follows:

- a) Refer to TABLE 2. Choose the row in the table that has the approximate load wattage for the intersection. Locate the percent figure in the chosen load wattage row that is closest to the percent you desire the Relay B-Low Batt. dry contacts to signal that the batteries are getting low. Note the letter (A through E) at the top of the column.
- b) Rotate the potentiometer fully counterclockwise (CCW).
- c) Rotate the potentiometer clockwise until the adjustment slot points at the letter selected in Step a (rotate 0° for A, 67° for B, 135° for C, 202° for D, 270° for E).

TABLE 2

Load Watt	Total Run Time (min)	Pot. Position:	E	D	C	B	A
		Batt. Voltage:	24.2	23.5	22.7	21.7	21.3
300	583	Battery run time percentage remaining	67%	38%	15%	3%	2%
500	546		72%	41%	17%	4%	2%
700	200		97%	52%	22%	5%	2%
900	139		99%	59%	26%	6%	3%

The front panel has a DB-9 female connector. This port allows the BBS system to be monitored and controlled using HyperTerminal (or other terminal emulation software) on a Windows based PC. Refer to section 6.2 Terminal Setup, for a tutorial of this interface.

6.1 Connecting the RS-232 Port

Connect a standard computer cable between the computer's RS-232 port and the BBS unit's RS-232 port.

6.2 Terminal Setup

6.2.1 HyperTerminal Setup

This section gives step-by-step procedures for configuring the HyperTerminal interface. Before proceeding the user must determine which PC Com port the BBS is connected to. In this example, Com1 is being used. This will typically be the correct choice for most users and their PC's.

Refer to screen figures on page 24

- 1 From the Windows Start menu go to:
Programs/Accessories/ Communications/HyperTerminal and click the Hyper Terminal entry/icon.
- 2 The **Connection Description** window shown in Figure 16 appears. Enter a name and select an icon for your unit and click **OK**. A sample name appears in Figure 16. When all setup has been completed, this will be the HyperTerminal file name that can be accessed without having to re-initialize the setting.
- 3 The **Connect To** window shown in Figure 17 appears. In the "Connect using" drop-down box select 'COM1' or 'Direct to Com1' and click **OK**.
- 4 The **COM1 Properties** window shown in Figure 18 appears. Set each Port Settings field as shown in Figure 18 and click **OK**.
- 5 The blank terminal interface screen appears as shown in Figure 19. On the File menu go to properties and click once.
- 6 The **'BBS (ADI-24M11 5th & Vine in this case) Properties'** window appears. Click on the **Settings** tab. Fill in the fields as shown in Figure 20. Click the **ASCII Setup** button.
- 7 The BBS (ADI-24M11 5th & Vine in this case) **'ASCII Setup'** window appears. Fill in the fields as shown in Figure 21. Click the **OK** button.
- 8 The **'BBS (ADI-24M11 5th & Vine in this case) Properties'** window reappears (Figure 20). Click the **OK** button.
- 9 HyperTerminal Setup is now finished. The blank terminal interface window reappears as in Figure 19. Press the ENTER key to begin accessing the unit with RS-232 serial communications. The Dimensions BBS interface screen appears as in Figure 22. Go to Section 6.3 page 26 to begin using the BBS Communications interface.



FIGURE 16



FIGURE 17

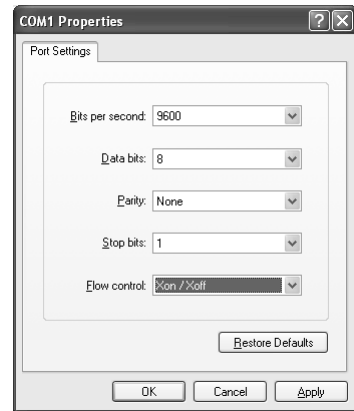

FIGURE 18

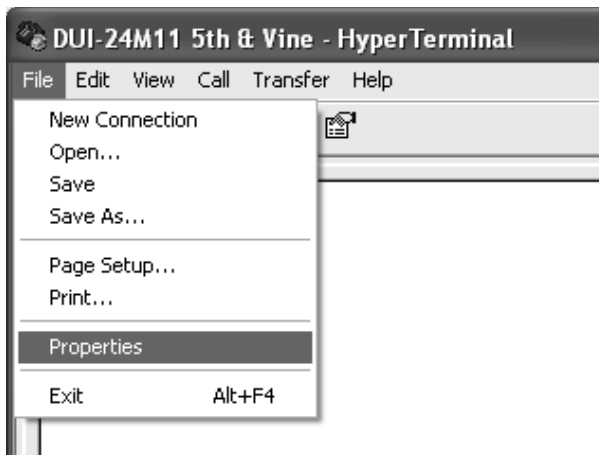

FIGURE 19

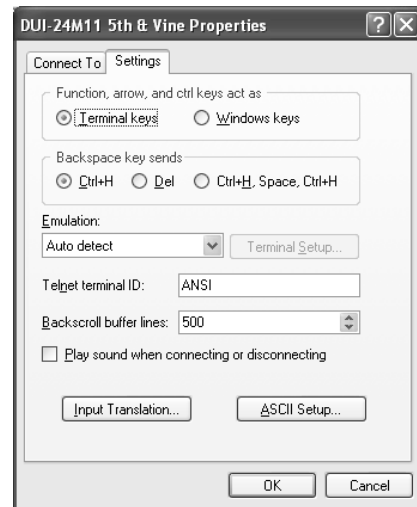

FIGURE 20

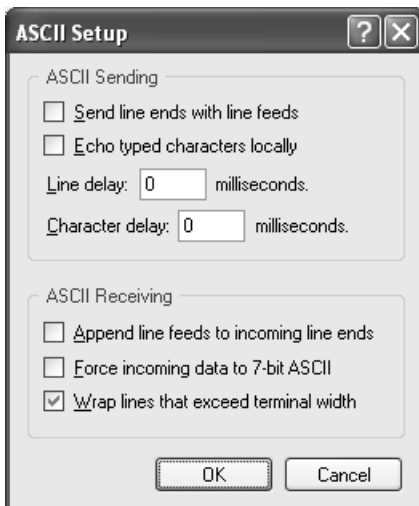

FIGURE 21

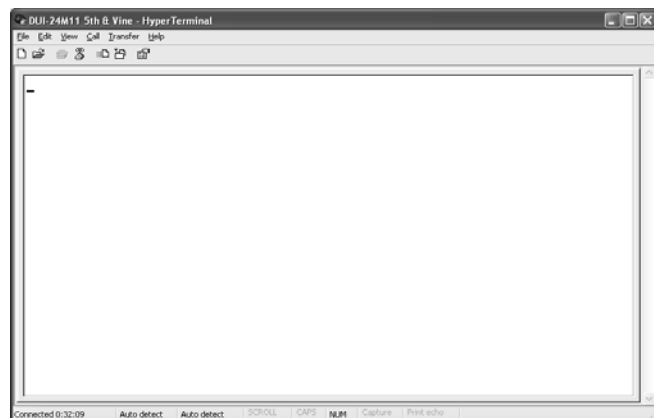

FIGURE 22

6.2.2 HyperTerminal Log File

HyperTerminal is capable of logging the terminal session in a text file for later viewing or data transfer. To initiate a log file use the following steps.

1. From the **Terminal Interface** window click '**Transfer**' menu then click '**Capture Text**'. See Figure 23 below.
2. The '**Capture Text**' window appears see Figure 24 below. Enter a path and file name appropriate for the BBS unit. The example uses a date and intersection to designate the BBS. When finished click the **Start** button. The communication session will now be logged. The file will be saved automatically upon exit of HyperTerminal.

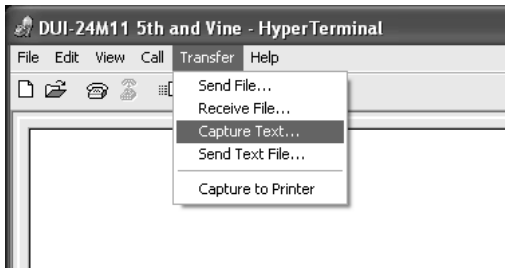

FIGURE 23

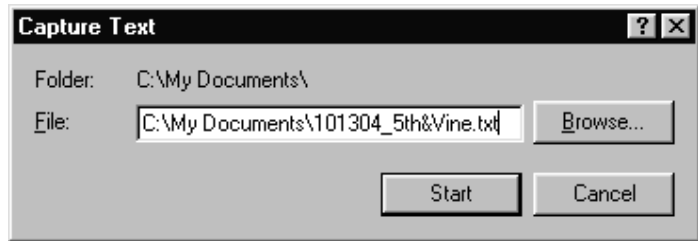

FIGURE 24

6.2.3 Other Terminal Emulation Setups

If another terminal emulation software package is used, the parameters in Table 3 will be needed to communicate with the BBS unit.

TABLE 3: Terminal Emulation Setting

Emulation Type	VT100 or compatible
Duplex Mode	Half Duplex
Xon/Xoff Flow Control	ON
RTS/CTS Flow Control	OFF
Line Wrap	ON
Screen Scroll	ON
CR Translation	CR
Back Space	N/A
Break Length	N/A
Inquiry	NA
Handshaking	Software
Baud Rate	9600
Data Format	8 Data, No Parity, 1 Stop Bit

6.3 Using the BBS Communication Interface

The Dimensions BBS Communications Interface, for simplicity, is only 1 level deep. This section describes the STATUS information entries and use of the UPS COMMANDS.

Airpax Dimensions, Inc.		MM, DD, YY	HH:MM
Traffic BBS Serial Interface		(model number)	(serial number)
BBS STATUS AC Transfer Pts: 100-130 VAC BBS Mode: Backup/Standby Utility Line: Invalid Outage Counter: 1 Total Outages: 10 Run Time: 1 Hrs 1Min Total Run Time: 10 Hrs 1Min Batt. Voltage: DC Volts Batt Full: Yes/No Check Batt.: Yes/No Low Batt. Relay: On/Off Timer Relay: On/Off Overload: Yes/ No High Temp: Yes/No		BBS COMMANDS Set Time (1) Set Date (2) Status Update (3) Reset Outage Meter (4) Reset Run Time Meter (5) Display Event Buffer (6) Change AC Level Setting (7) Model Number (8) Serial Number (9)	

FIGURE 25: BBS Communications Interface Screen

6.3.1 Status: Refer to Figure 25 for the location of the STATUS and BBS COMMANDS

- 1) **AC Transfer Pts.:** Displays the current setting of the AC transfer threshold pts. See Section to change.
- 2) **BBS Mode:** Displays whether the BBS is in Standby or Backup mode. When in Backup mode this also indicates that 'On Batt-Relay A' is active.
- 3) **Outage Counter:** Displays the current number of outages since the Outage meter was last reset.
- 4) **Total Outages:** Displays the total number of outages since the BBS was installed.
- 5) **Run Time:** Displays the current Run Time of the unit since the Run Time meter was last reset.
- 6) **Total Run Time:** Displays the total Run Time of the unit since the BBS was installed.
- 7) **Batt. Voltage:** Displays the current battery voltage.
- 8) **Batt. Full:** Indicates that the battery bank is fully charged.
- 9) **Check. Batt.:** Indicates a problem with the batteries or the charger.
- 10) **Low Batt. Relay:** Indicates that the battery bank has reached the Remaining Capacity point set in Section 5.1 and that 'Low Batt-Relay B', is active.
- 11) **Timer Relay:** Indicates that the BBS has been in backup mode for 2 hours and that 'Timer-Relay C', is active.
- 12) **Overload:** Indicates that an overload condition exists.
- 13) **High Temp:** Indicates that a high temperature condition exists.

6.3.2 Commands

- (1) **Set Time:** Set the time in the following 24HR format hh:mm.
- (2) **Set Date:** Set the date in the following format. mm/dd/yy.
- (3) **Status Update:** Press to update the display with current BBS information.
- (4) **Reset Outage Meter:** Resets both the internally stored Outage Counter and the external Outage Meter. The unit will keep a total running count of all outages.
- (5) **Reset Run Time Meter:** Resets both the internally stored current Run Time Meter and the external Run Time Meter. The unit will keep a total run time for the life of the unit.
- (6) **Display Event Buffer:** Scroll out the BBS events to the display. All events are stamped with the date and time. Events supported are:
 - Utility Failure-current number of outages displayed (BBS is in backup mode, Relay A is activated).
 - Utility Restore-run time for the current outage displayed.
 - Low Batt.-The useful battery capacity has reached the level set by the potentiometer on the unit, Relay B is activated.
 - 2HR Outage-The BBS has been in backup mode for 2 hours.
 - Protective shutdown-The BBS reached the low voltage shutdown level and shutdown to prevent deep discharge.
 - Power Up-the unit has been turned on after being off.
 - Serial Access Start-Serial communications have begun.
 - Serial Access Stop-Serial communications have been terminated.
 - Program Change-AC Level, Outage Reset, or Run Time Reset will be displayed (one listing for each instance).
 - BBS Failure listings (TBD).
 - Change AC Level Setting.
 - Switches AC threshold range between Generator (95-134VAC) with restores at 100, 129 and Standard (100-130VAC) with restores at 105, 125.Press "Esc" to return to the BBS Communications Interface Screen.
- (7) **Change AC Level Setting:** Switches AC threshold range between Generator (95-134VAC) with restores at 100, 129 and Standard (100-130VAC) with restores at 105, 125
- (8) **Model Number:** Enter the model number of the unit using ASCII-Numeric text (8 characters maximum).
- (9) **Serial Number:** Enter the serial number of the unit using ASCII-Numeric text (8 characters maximum).

6.3.3 Exiting HyperTerminal:

At any time you may terminate the terminal session by using File/Exit or clicking the X button

7.1 Systems Description:

7.1.1 General Overview: Dimensions Battery Backup Systems (BBS) consists of four main components: The BBS module with a built-in battery charger, the manual bypass switch (MBPS), 30A transfer relay (30ATR) or the Combined Manual Bypass Switch (MBPS-30ATR), and two or four 12VDC AGM sealed batteries along with the DC and AC cable connectors.

7.1.2 BBS Module: The BBS module has two basic modes of operation described below: Inverter mode and Standby mode. The Inverter mode operation can be either "full power" backup or "red flash" operation (see dry-relay wiring configuration below).

1) Inverter Mode: The direct current (DC) that enters the inverter from the batteries is filtered by a large input capacitor and switched "On" and "Off" by the Metal Oxide Silicon Field Effect Transistors (MOSFET) at a rate of 60 cycles per second, and fed into the transformer which steps the voltage up to 120 volts. The inverter has a 16 MHz microprocessor to control the output voltage and frequency as the DC input voltage and/or output load varies. The 120VAC, 60Hz voltage signal output waveform generated by the inverter is called pure sine.

1.1) Full Power Backup: The BBS was designed to supply full backup power within the BBS rating. No dry-relay wiring connection is needed.

1.2) Red Flash Mode Operation: The BBS can operate in "Red Flash Mode" by wiring the appropriate dry relay contacts to the traffic light controller red flash switch circuit. There are three (3) double-pole double-throw (DPDT) dry relay contact closures (NO: Normally Open, C: Common and NC: Normally Closed), available on two terminal blocks (one side of each relay on each block) with #6/32 screw terminals rated at a minimum 120V/1A, and labeled so as to identify each contact, see Figure 14, page 20. The terminal block wiring is protected with a clear plastic cover. There is a corresponding LED indication when each relay is activated, see Figure 1, items (7), (8) & (9) on page 5. All relays are deactivated when the inverter switch is off.

The Dry relay contacts energizes as follows:

a) The "On Batt." Relay Contact A (NO, C, NC): These relay contact closures are energized whenever the unit switches to Inverter mode (Battery Backup).

b) The "Low Batt." Relay Contact B (NO, C, NC): These relay contact closures are energized whenever the battery approaches the useful battery capacity remaining reference point (40% in most applications) chosen by the user. See settings on section 5.1, page 21.

c) The "Timer" Relay Contact C (NO, C, NC): These contact closures are energized two hours after the unit switches to Inverter mode (Battery Backup).

2) Standby Mode: External power (120 VAC, 60 Hz) is connected to the inverter through the MBPS and the 30ATR or the CMBPS-30ATR. The BBS module automatically senses and qualifies external utility power, switching the inverter “Off” and the battery charger “On”. All the loads attached to the BBS module output will operate directly from the external power line. The BBS internal transfer relay will automatically switch the system back to Inverter mode if the external power fails.

7.1.3 CMBPS: Rated at 240 VAC and 30 amps, this is a stand-alone switch is used to isolate the BBS module manually during maintenance operation.

7.1.4 30ATR: Rated at 240 VAC and 30 amps, this transfer relay is automatically energized to ensure that continuous flow of external power reaches the traffic light controller. In the event of an internal BBS failure, it defaults to the external power line, thus isolating the BBS module

7.1.5 CMBPS-30ATR: Rated at 240 VAC and 30 amps, this “combo switch” alone accomplish the functions of the CMPBS and the 30ATR together.

7.1.6 Deep Cycle – AGM/VRLA Batteries: Deep cycle batteries are designed specifically for repetitive charge and discharge cycles. These batteries are also made to be discharged to a very low level before recharging. Their plates are thicker than the common automotive starting batteries. Deep cycle battery power capacity is rated in amp hours with a given discharge time typically at 20 hours. A 100-amp hour battery will produce five amps for twenty hours before it is exhausted.

AGM/VRLA (Absorbed Glass Mat/Valve Regulated Lead Acid) are maintenance-free batteries. The liquid electrolytes of AGM/VRLA batteries have been absorbed into fiberglass cloth mats between the plates. They have good deep cycle characteristics and can be used in most positions. They are less affected by temperature extremes but are more sensitive than other types of batteries. AGM/VRLA batteries do not tolerate storage at a low state of charge but will handle overcharging slightly better.

7.1.7 Battery Cable Assembly: The quick interconnect battery cable assembly typically has a length of 12 inches between batteries and 60 inches between the BBS unit and the first battery. The cable assembly consists of 8-gauge welding style cable UL listed super K90 and an 80-amp fuse. The cable assembly is equipped with insulated, mating, power pole style connectors. Two-piece power pole style connectors are used, Positive (+) red and Negative (-) black. The power pole connectors ensure proper polarity and circuit configuration throughout the entire harness. See Figure 10 page 13.

The quick interconnect two-piece battery cable assembly harness consists of:

- Six inches of appropriate colored cable with ¼ inch ring terminals for connecting to the battery terminal and the appropriate colored modular power pole style connector. Battery terminals are covered and insulated with appropriate colored molded boots.
- Two-piece mating power pole style connectors for connecting to the batteries and a single insulated power pole connector for connecting to the BBS unit.

7.1.8 System Block Diagram:

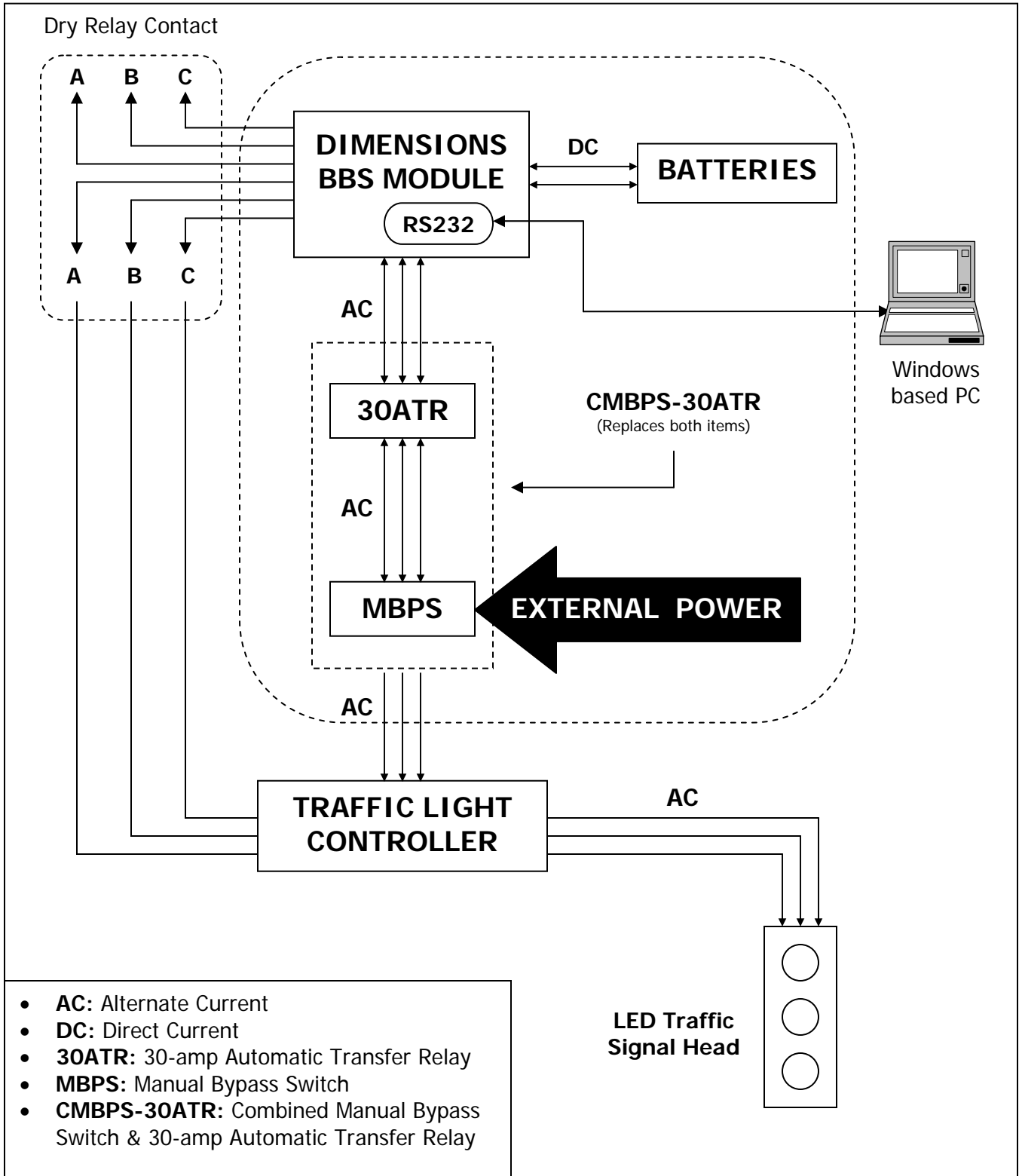

Figure 25: BBS block diagram

7.2 Startup Procedure

7.2.1 General: After correct installation the BBS may be activated. The BBS automatically switches to the standby mode any time a qualified external AC power source is present. The 30ATR is also always de-energized when qualified external AC power is present or when a fault in the inverter line is been detected. The 30ATR cannot be defeated.

The inverter mode is second priority to the Standby mode and can only be activated when there is no qualified external AC power source. The inverter must be left on and the BBS will automatically and safely cycle back and forth between Standby and Inverter modes.

7.2.2 Things to Check Before Turning the BBS to On:

- **Output and Input Breakers:** Make sure the breakers are reset.
- **Temperature Compensated Cable:** Make sure the temperature compensated cable is connected as instructed in section 4.4.1, page 15 to ensure proper battery charging.

7.2.3 Turning the Inverter “On” or “Off”: To activate the inverter, set the switch on the front of the BBS module to the “On” position, the green LED “Inverter On” will come on.

7.2.4 Manual Bypass Switch (MBPS): After the inverter is switched to “On”, set the manual bypass switch to “BBS Mode”.



*To prevent current being withdrawn from the batteries that results in battery damage the inverter unit **must be** switched “Off” and the batteries **must be** disconnected from the inverter at the Anderson connector if the Manual Bypass Switch is in the “Bypass” position.*

7.2.5 Combined Manual Bypass Switch & 30-amp Automatic Transfer Relay (CMBPS-30ATR): After the inverter is switched to “On”, set the manual bypass switch to “BBS Mode”.



*To prevent current being withdrawn from the batteries that results in battery damage the inverter unit **must be** switched “Off” and the batteries **must be** disconnected from the inverter at the Anderson connector if the Manual Bypass Switch is in the “Bypass Mode” position.*

Maintenance & Troubleshooting Section 8



To prevent current being withdrawn from the batteries that results in battery damage the inverter unit ***must be*** switched “Off” and the batteries ***must be*** disconnected from the inverter at the Anderson connector if the Manual Bypass Switch is in the “Bypass Mode” position.

8.1 Preventive Maintenance:

8.1.1 BBS Module Maintenance: The BBS module was designed to be maintenance-free. There are no serviceable parts inside the unit.

It is recommended to do a cleaning routine maintenance as follows:

- Clean the cover of the BBS as needed using a damp cloth or nonabrasive cleanser.



Do not use ACETONE-BASE cleaning solutions. Keep cleaning solutions out of the electrical receptacles on this device.

8.1.2 Battery Maintenance: The BBS uses sealed maintenance-free batteries. Proper charging and limited cycling along with a proper battery environment will ensure a long battery life.



Servicing of batteries should be performed or supervised by authorized personnel at least four times a year.



A battery can present a risk of electrical shock and high short circuit current.

- Clean and tighten battery connections.
- All battery connections should be examined and checked for corrosion.
- Replace batteries when conductance tests indicate 30% to 40% deterioration from the original value. Use a battery conductance tester, Dimensions part number 290003.
- When replacing batteries, use the same model number and type batteries. Batteries should be replaced in complete sets.
- Before proceeding with installation, review battery system drawings and assembly according to provided instructions.
- Normal battery operating temperatures are between 68°F (20°C) and 77°F (25°C).

8.2 Trouble Analysis:

8.2.1 General Troubleshooting:

a) Inverter Troubleshooting Procedure: Isolate the BBS completely out of the external power by setting the MBPS to "Bypass Mode" and do the following:

- Set the BBS module powers switch to "Off".
- Unplug the female and male connector cords coming out from the BBS module and from the 30ATR or the CMBPS-30ATR.
- Check that all the circuit breakers are reset, including the one on the front of the BBS module, see section 3.1, and Figure 1 items (1) and (2) on page 5.
- Connect a 100-watt light bulb to the female AC output receptacle cord coming out from the BBS module.
- Set the power switch to "On".
- Observe the LEDs on the front control panel. Follow troubleshooting table 5 on page 34, and the Troubleshooting Flowchart Figure 27, page 35.

b) 30ATR or MBPS-30ATR Troubleshooting Procedure: A problem with the 30 amp transfer relay is indicated when AC loads do not operate when the external AC power source is available. Perform the following troubleshooting steps:

- Set the MBPS to "Bypass Mode"
- Set the BBS module power switch to "Off"
- Unplug the female and male connector cords coming out from the 30ATR or CMBPS-30ATR and the BBS module.
- Connect a 100-watt light bulb to the female AC receptacle cord coming from the 30ATR or CMBPS-30ATR.
- Set the MBPS or CMBPS-30ATR switch back to "BBS Mode" to ensure that a proper source of external power is connected to the BBS module.
- If the bulb does not light, call Dimensions.

c) Battery Charger Troubleshooting Procedure: Make sure that the 30ATR or CMBPS-30ATR is in good standing by performing the troubleshooting steps suggested in (b). There is one yellow LED (check battery) on the control front panel that indicates a problem with either the battery bank or the DC cables.



Make sure that the remote temperature sense probe is installed correctly as instructed in section 4.4.1, page 15.

- Make sure there is a proper source of external power connected to the BBS module.
- Set the main power switch to "Off".
- Using a voltmeter check the DC current and voltage on the red battery wire.
- Follow the troubleshooting table 5 on page 34.

TABLE 5

LED Indicator	Problem	Solutions
<p>1 No LEDs</p>	<ul style="list-style-type: none"> The BBS module is not connected to the batteries. The battery voltage is below 9 volts DC. 	<ul style="list-style-type: none"> Check the in-line fuses for continuity. Make sure the DC wires are clean and tight. Check the DC voltage at the inverter DC input. Using a voltmeter connect the probes to the <i>"Battery Voltage Test Point"</i> jacks for this purpose.
<p>2 Low Battery Red LED</p>	<ul style="list-style-type: none"> Indicates that the BBS module has shut off due to a low battery voltage condition. Typically at 21 VDC. 	<ul style="list-style-type: none"> Fault in the battery wiring, battery capacity and voltage or the in-line fuse. Check the DC voltage at the inverter DC input. Using a voltmeter connect the probes to the <i>"Battery Voltage Test Point"</i> jacks for this purpose.
<p>3 Overload Red LED</p>	<ul style="list-style-type: none"> Indicates that the BBS module has shut off due to an overload condition. 	<ul style="list-style-type: none"> The inverter output wiring is shorting or loads exceed the inverter rating. This indicator will automatically clear or the inverter will shut off. Remove the short circuit or excessive load from the output, and then switch the inverter off then on. If the condition persists, call Dimensions.
<p>4 High Temp. Red LED</p>	<ul style="list-style-type: none"> Indicates that the BBS module has shut off due to high internal temperature. The unit will automatically turn back on when it has cooled to 40°C (104°F). 	<ul style="list-style-type: none"> Verify that the BBS module is in a vented compartment and that the fan is not blocked. High ambient temperatures combined with poor ventilation may also contribute to the shut down.
<p>5 Chk Batt Check Battery Yellow LED</p>	<ul style="list-style-type: none"> Indicates that the charger is operating in a low or high DC output voltage condition. The charger will shut off and will automatically turn back on when the condition is removed. 	<ul style="list-style-type: none"> Shorted or defective battery. Make sure that the DC cable connections are tight and clean and not shorted, and that the proper wire gauge is used. There is another source of battery charging or there is a defective battery charger. Disconnect and reconnect the external AC power to restart the battery charger. Check battery wiring or remove other source of battery charging.

8.2.2 BBS Module Troubleshooting Flow Chart

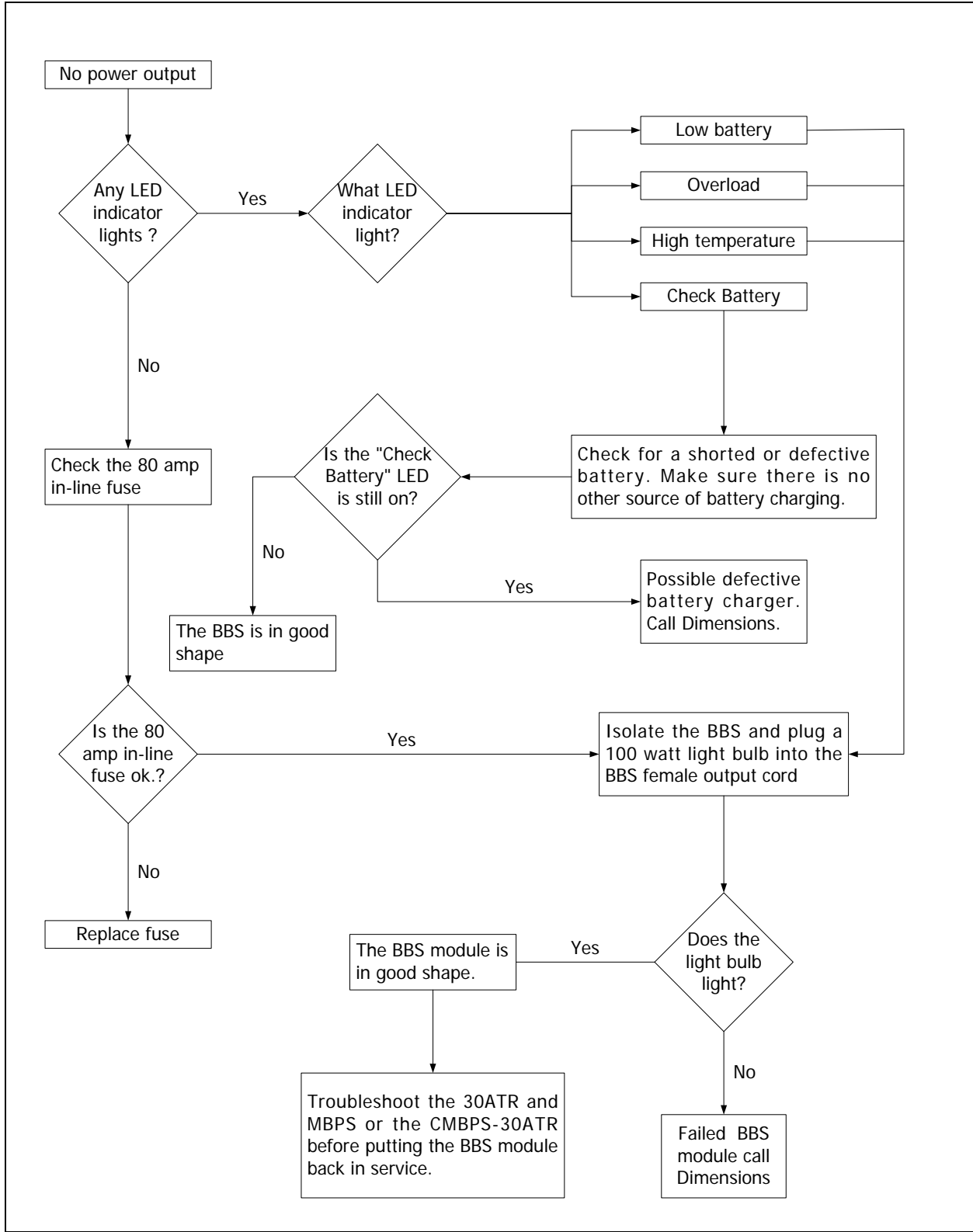

FIGURE 27: Troubleshooting Flow chart

Parts List

Section 9

Part Number	Description
140056	Guard fan metal
140251	Chassis base
140252	Chassis Cover
141217-1	Swing out battery shelf 79AH
141226-1	Swing out battery shelf 105AH
141272	Mounting bracket - Right
141273	Mounting bracket - left
210095	RS-232 9-Position connector
210160	Temp. Comp. Cable male plug
210162	Temp. Comp. Cable male pin
210169	Terminal block 9-position
250274	Screw 10-32X1
250275	Washer # 10
260060	Fan
290003	Battery conductance tester
295003	Digital meter - Hour
295004	Digital meter - Counter
390003	AGM Battery with handle 12VDC 79AH
390006	AGM Battery with handle 12VDC 105AH
430013	Circuit Breaker 15A
451036	MBPS – Manual Bypass Switch (right mount)
451036-1	MBPS – Manual Bypass Switch (left mount)
475007	Potentiometer
511015	30ATR- 30 amps Automatic Transfer Relay
560158	Transformer
611252	Access terminal block dry relay cable assembly with quick connector
611260	Battery interconnect cable 24V – 4 battery, 1 meter
611448	Battery interconnect cable 24V – 2 battery, 2 meters
611455	Temp. Compensated Cable Assembly
611488	Battery interconnect cable 24V – 4 battery, 2 meters Caltrans

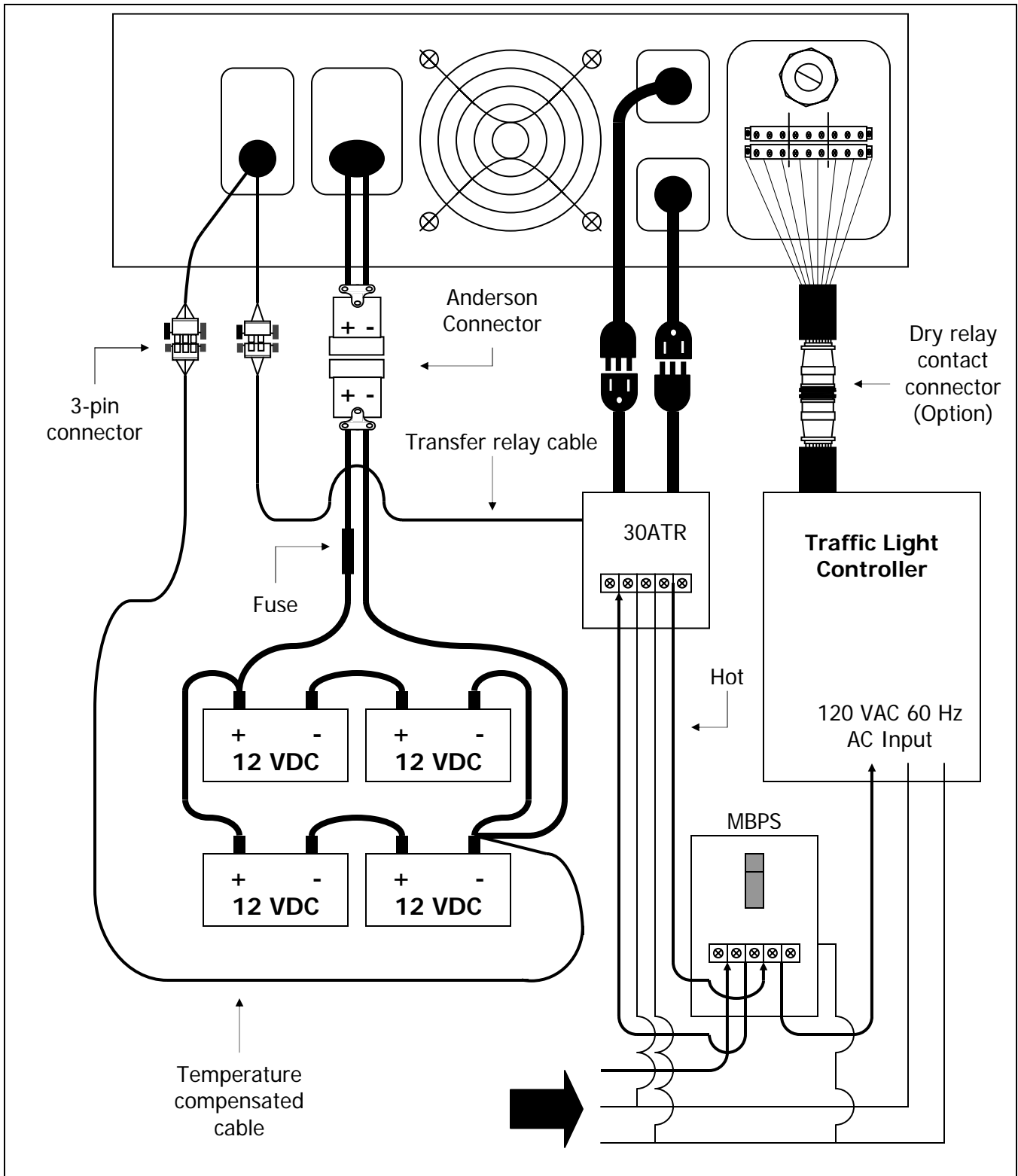

FIGURE 28: Wiring Diagram Complete System

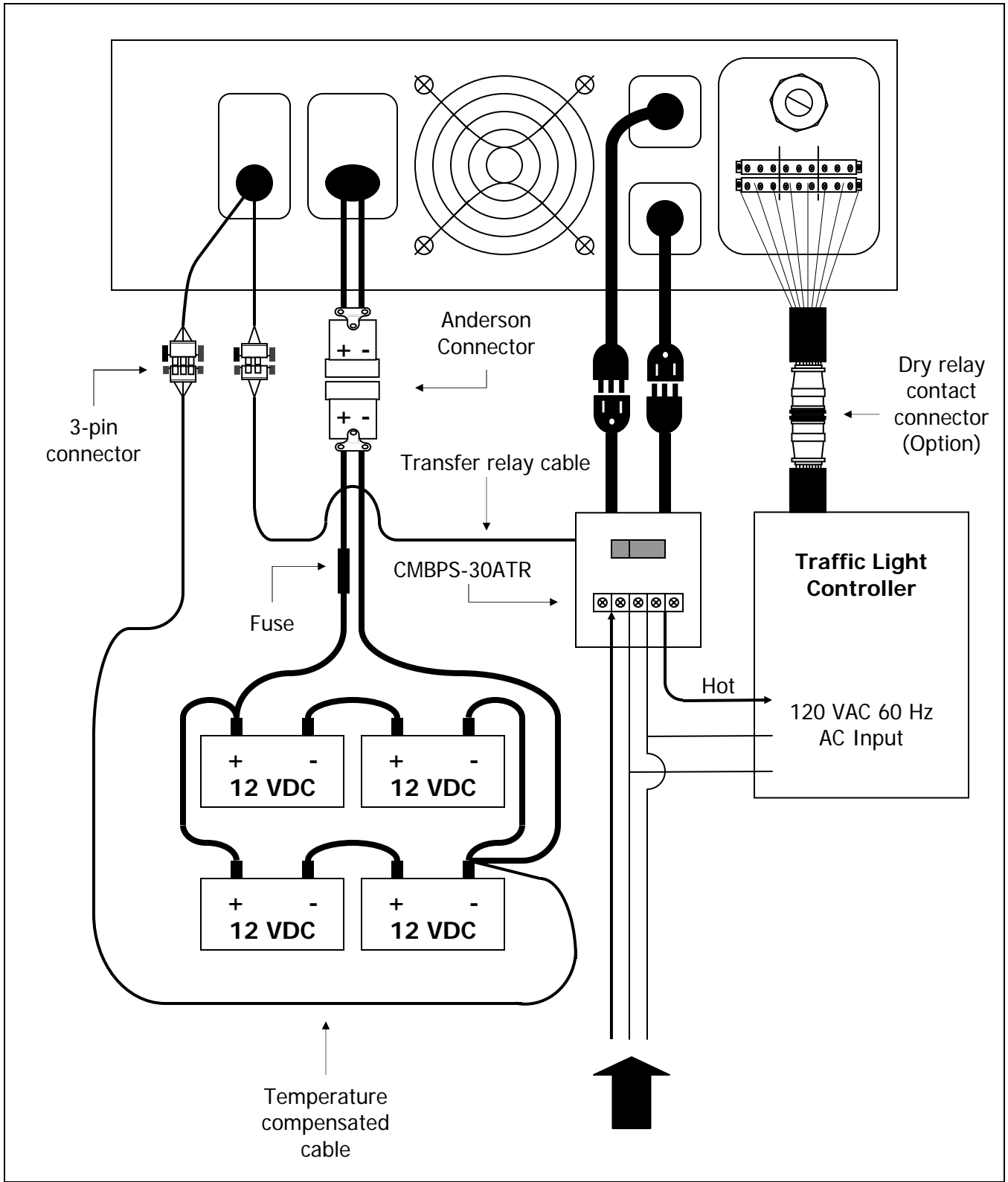

Figure 29: Wiring Diagram, Complete System with CMBPS-30ATR

Limited Warranty

Section 11

SHIPPING TERMS: F.O.B. St. Paul Minnesota. Freight prepaid and billed, subject to prior credit approval.

MINIMUM ORDER: \$50.00 Net Price

LOSS OR DAMAGE: Loss or damage in transit is the responsibility of the carrier. Any claim should be filed with the delivering transport company. Invoice, Bill of Lading and Delivery receipt with damage noted therein must accompany any claims for freight damage. Claims for shortage and lost shipments must be made in writing to Sensata Technologies, St. Paul, MN within 10 days of date of shipment. Claims not reported within this time frame will not be honored.

PRICES: Prices are subject to change without notice. All orders are subject to acceptance at the factory. We reserve the right to invoice prices in effect at time of shipment.

TERMS: Net 30 days with approved credit, credit card or C.O.D.

RETURN GOODS POLICY

No returned materials will be accepted without an accompanying Returned Materials Authorization Number (RMA) from factory.

Credit will be issued for returned goods to the original purchaser within 60 days of purchase, provided the inverter is returned to Sensata unused and not mounted. The amount of credit will be issued at Sensata discretion based on the condition of the product.

Customer must be in good standing with Sensata Technologies.

Inverters that are discontinued, high-voltage (over 24vdc), special-order or used are excluded and will not be eligible for credit. Non-inverter items such as cable assemblies, fuses and fuse holders, will not be eligible for credit

Support components supplied by Sensata vendors will be covered under that manufacturer's credit return policy.

Customer pays return freight.

PLEASE SHIP FREIGHT PREPAID AUTHORIZED RETURNS TO:

Sensata Technologies, Inc. / 4467 White Bear Parkway / St. Paul, MN 55110

LIMITED WARRANTY: Sensata Technologies warrants to the original purchaser for use that the goods or any component thereof manufactured by Sensata Technologies will be free from defects in workmanship for a period of 5 years from the date of purchase, provided such goods are installed, maintained and used in accordance with Sensata Technologies and the original manufacturer's written instructions.

Components not manufactured by Sensata Technologies, but used within the assembly provided by Sensata, are subject to the warranty period as specified by the individual manufacturer of said component, provided such goods are installed, maintained and used in accordance with Sensata Technologies and the manufacturer's written instructions.

Sensata Technologies sole liability and the Purchaser's sole remedy for a failure of goods under this limited warranty and for any and all claims arising out of the purchase and use of the goods, shall be limited to the repair or replacement of the goods that do not conform to this warranty. The return of the purchase price in cash is at the sole discretion of Sensata.

To obtain repair or replacement service under the limited warranty, the purchaser must contact the factory for a Return Material Authorization (RMA). Once obtained, send the Return Material Authorization Number along with the defective part or goods to: Sensata Technologies Inc., 4467 White Bear Parkway, St. Paul, MN 55110, freight prepaid.

THERE ARE NO EXPRESS WARRANTIES COVERING THESE GOODS OTHER THAN AS SET FORTH ABOVE. THE IMPLIED WARRANTIES OF MERCHANTABILITY AND FITNESS FOR A PARTICULAR PURPOSE ARE LIMITED IN DURATION TO ONE YEAR FROM DATE OF PURCHASE.

SENSATA TECHNOLOGIES ASSUMES NO LIABILITY IN CONNECTION WITH THE INSTALLATION OR USE OF THE PRODUCT, EXCEPT AS STATED IN THIS LIMITED WARRANTY. SENSATA TECHNOLOGIES WILL IN NO EVENT BE LIABLE FOR INCIDENTAL OR CONSEQUENTIAL DAMAGES.

WARNING: LIMITATIONS ON USE: Sensata Technologies products are not intended for use in connection with Life Support Systems and for Avionic use. Sensata Technologies makes no warranty or representation in connection with their products for such uses.